



THE TECH BUBBLE: YEAR 5+

Or why you should stop listening to tech pundits
and why 2017 will be a good year for tech

A white plastic doll with a surprised expression is being pushed into a red rocking horse by a yellow rod. The doll is positioned on the left, and the rocking horse is on the right. The background is a solid yellow color.

First, the bad news...

FIRST RULE OF TECH: IT'S ALWAYS A BUBBLE

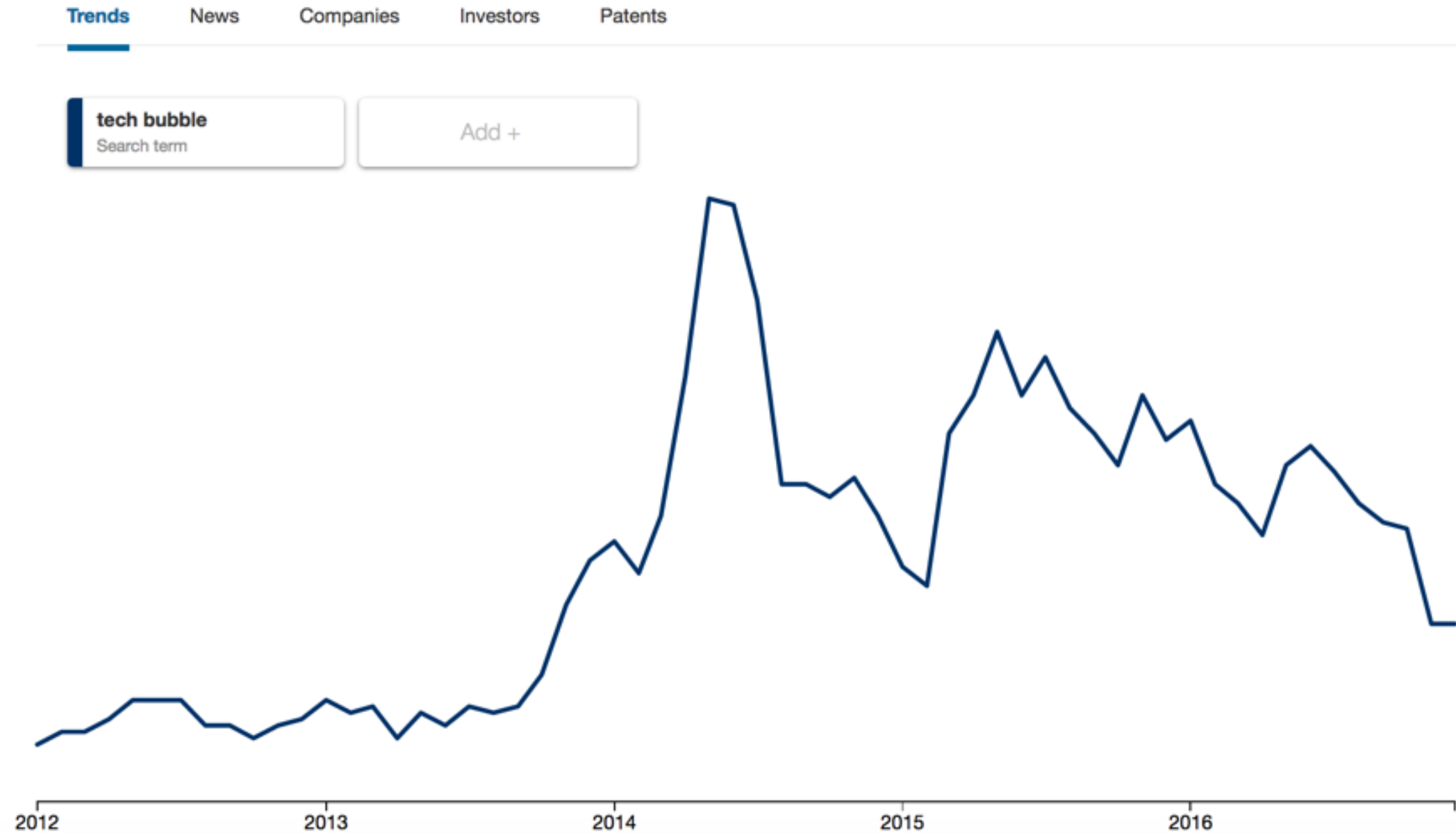

LOTS OF SMART FOLKS TALKING BUBBLE



“It’s been a steady sequence of very large rounds. It means we are in bubble territory...No one wants to say because nobody wants to break it. Everybody wants to cash out before its over....We are seeing expansion of valuation even from the seed stage all the way up...(There is) desperation to not miss out on what will be the next big thing.”

George Zachary, CRV



As with so many of the telltale signs of a bubble, I have seen this before. When times are so good that executives are willing to disregard the difference between ethical and unctuous behavior, it’s just one sign that the end, relatively speaking, is near. It’s not the only sign. The over-supply of journalism jobs covering the technology industry, for example, is a good indicator.

Adam Lashinsky, Fortune



“Now there is a clear consensus that we are witnessing our second tech bubble in 15 years. What is uncertain is how much further the bubble can expand and what might pop it.

In our view the current bubble is an echo of the previous tech bubble, but with fewer large capitalization stocks and much less public enthusiasm.

David Einhorn, Greenlight Capital



“You know, this is a cyclical industry, and when times get good, they get really good. Last time we saw that was 1999 and many of the people at this conference might not have been paying attention, because they were in high school. But money is definitely freer flowing today than it was three or four years ago.”

Bill Gurley, Benchmark Capital

NEW RULES

Burn Rate Doesn't Matter

Posted Apr 5, 2015 by [Scott Nolan \(@scottnolan\)](#)

3,439
SHARES



REAL ESTATE GOING CRAZY



Joe Fernandez

@JoeFernandez



Real estate is crazy enough in San Francisco that I have been offered stock options as part of selling our house.

6:36 PM - 13 Mar 2015  San Francisco, CA, United States

98 RETWEETS 129 FAVORITES



THE BANKERS ARE SHOWING UP

BloombergBusiness

News Markets Insights Video

Why Bankers Are Leaving Finance for No-Salary Tech Jobs



2016 SAW A RESET IN GLOBAL FUNDING



GLOBAL FINANCING TRENDS TO VC-BACKED COMPANIES

Q1'15 - Q4'16

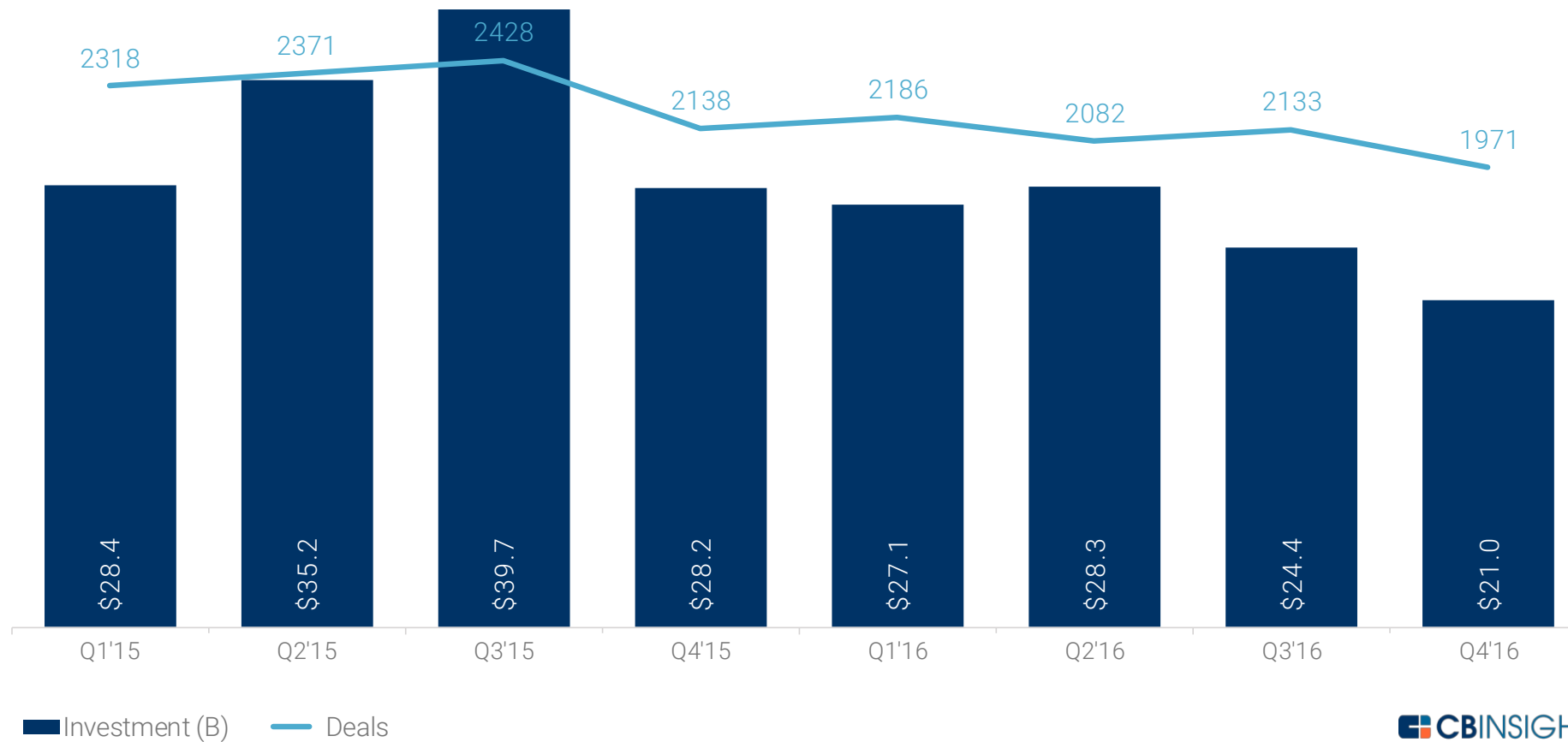

CBINSIGHTS

THE UNITED STATES WAS NO EXCEPTION

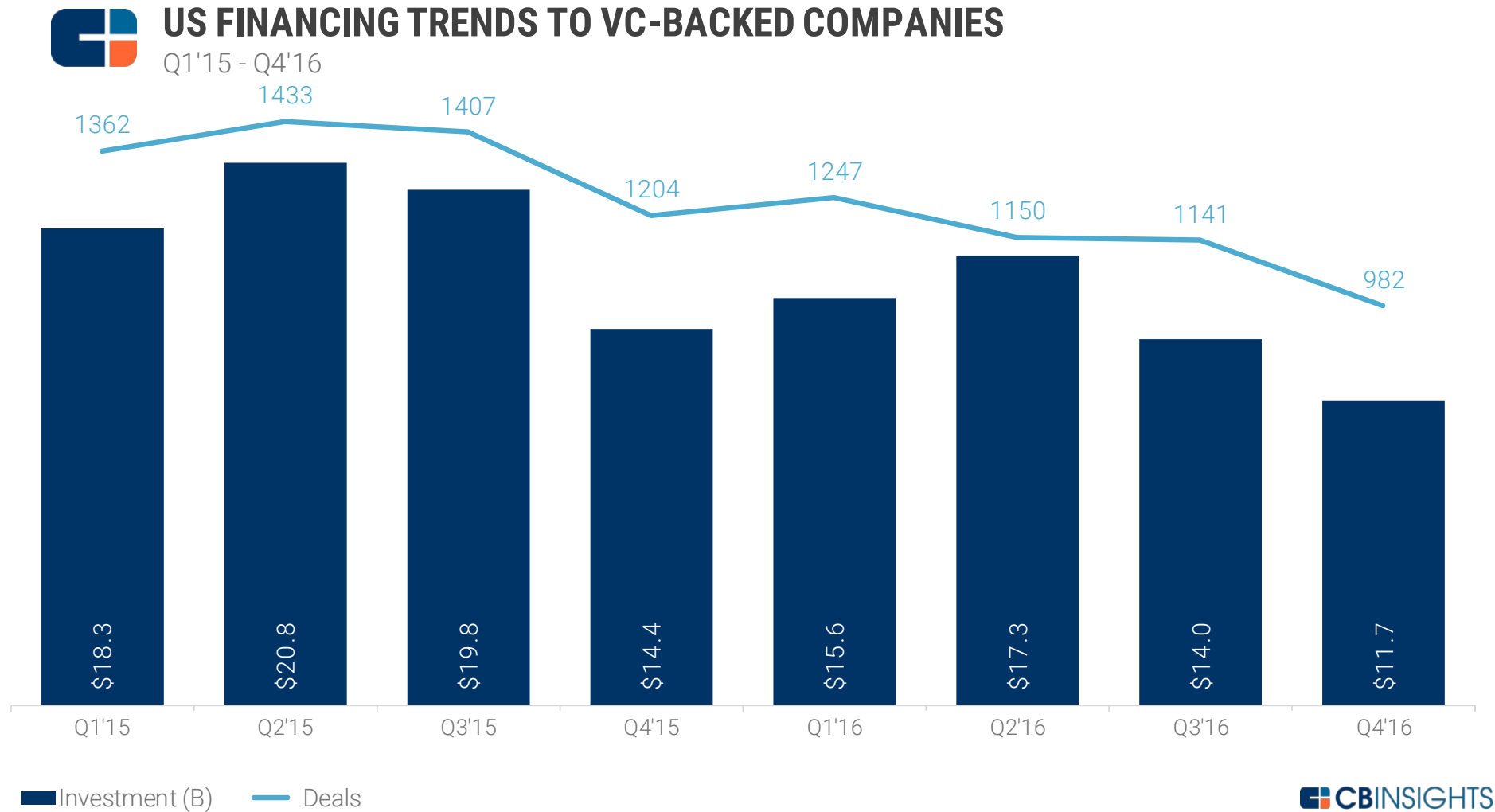

MEGA-ROUNDS CONTINUED TO DECLINE..

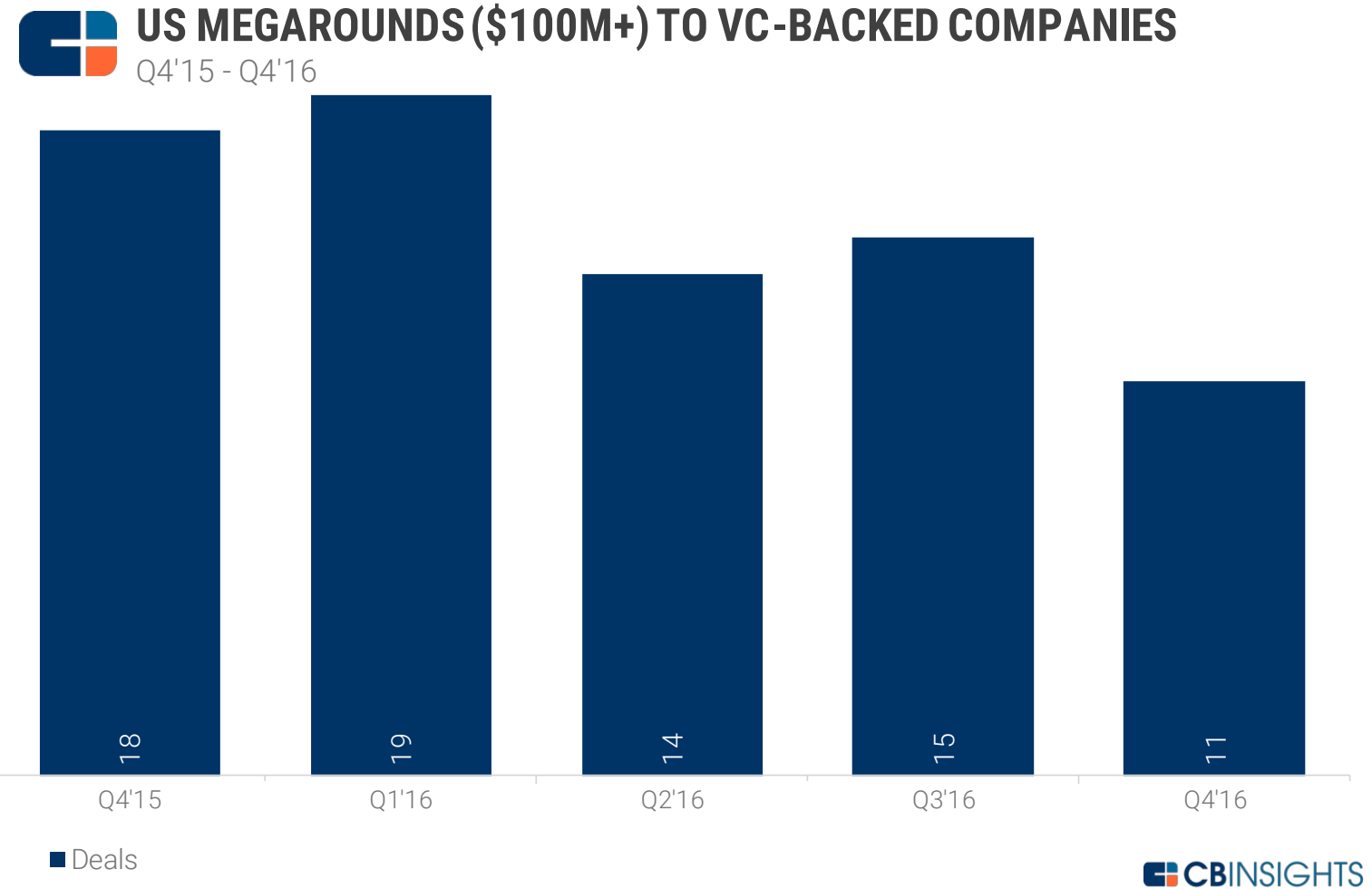

Download the full 48 page report at
cbi.vc/moneytree2016



WOUNDED UNICORNS OF 2016



ZENEFITS

JAWBONE®



Wandoujia



NANTHEALTH

GFG GLOBAL
FASHION
GROUP



home **24**

These 7 unicorns valuations were lowered last year, or exited at lower valuations than \$1B: [HelloFresh](#) (downround), [Home 24](#) (slipped below \$1B and was removed from the list), [Global Fashion Group](#) (downround), [Wandoujia](#) (exited), [Zenefits](#) (downround), [NantHealth](#) (IPO'd at a lower valuation), and [Jawbone](#) (downround).

AND UNICORN BIRTHS SLOWED

 **NEW US VC-BACKED UNICORNS**
(\$1B+ PRIVATE COMPANIES)

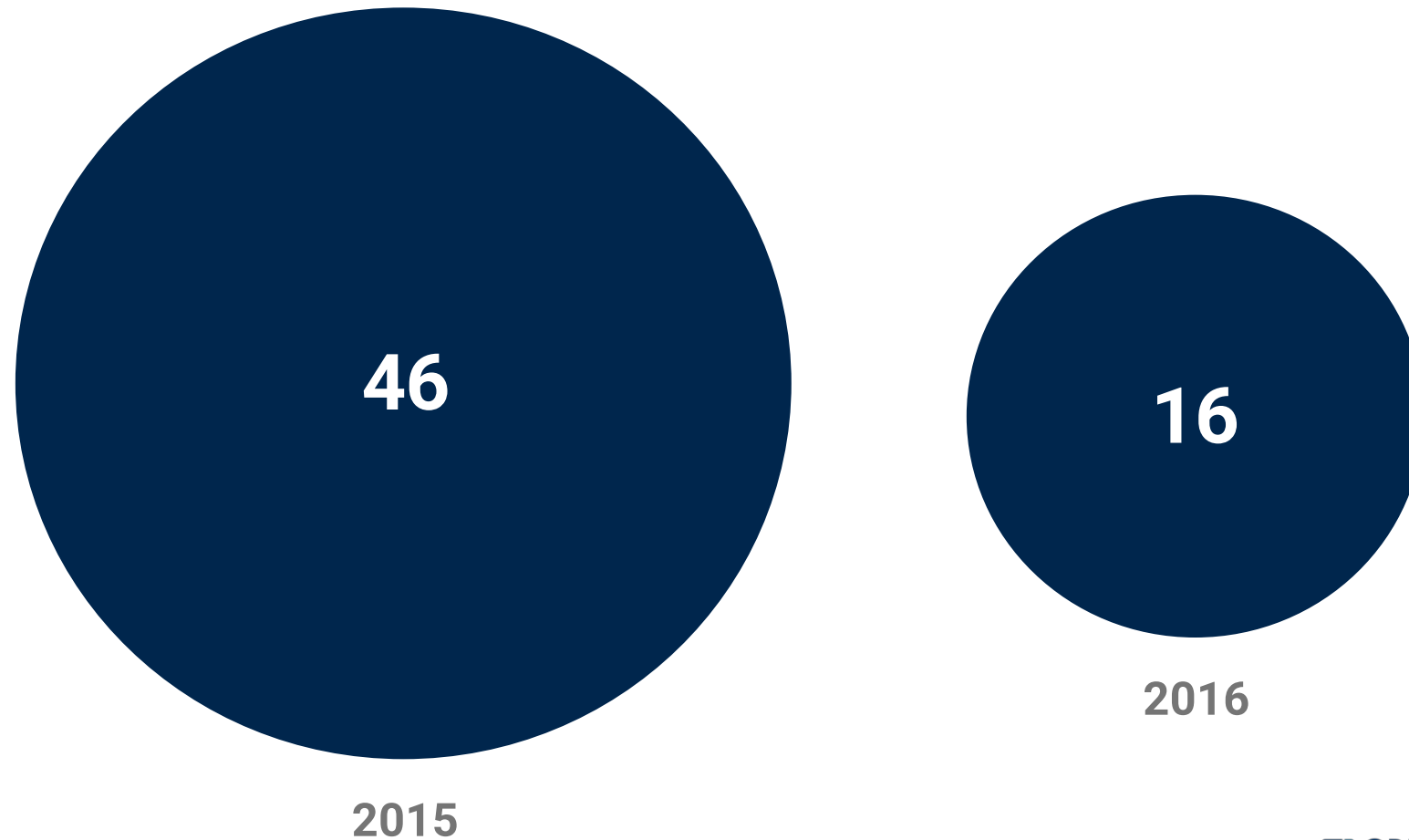

 CBINSIGHTS

LARGEST TECH CO M&A ACTIVITY IS DOWN

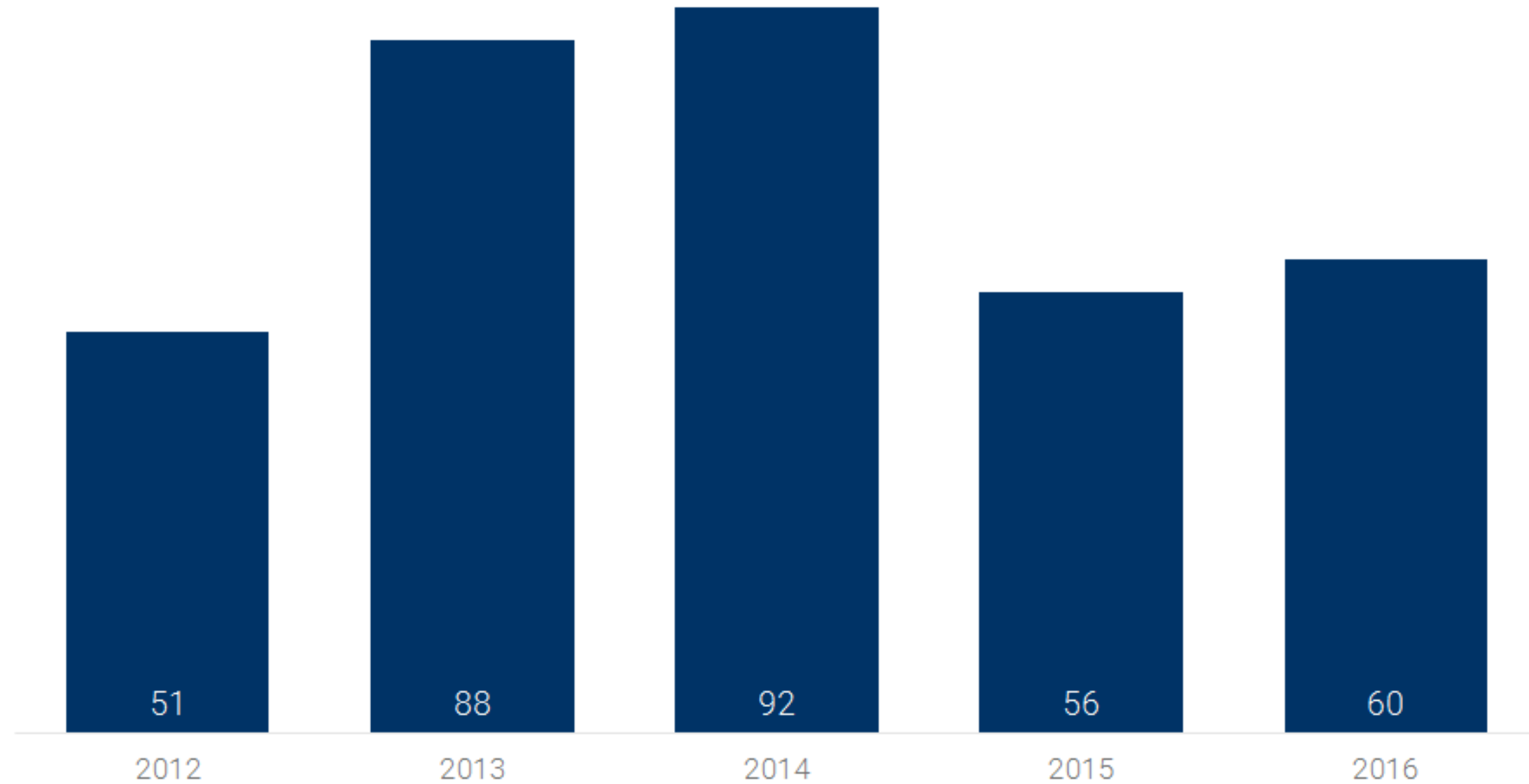

■ Aggregate M&A Of Select Internet Companies





GLOBAL M&A ACTIVITY: GOOGLE, YAHOO, FACEBOOK, APPLE, AND SALESFORCE

2012 - 2016

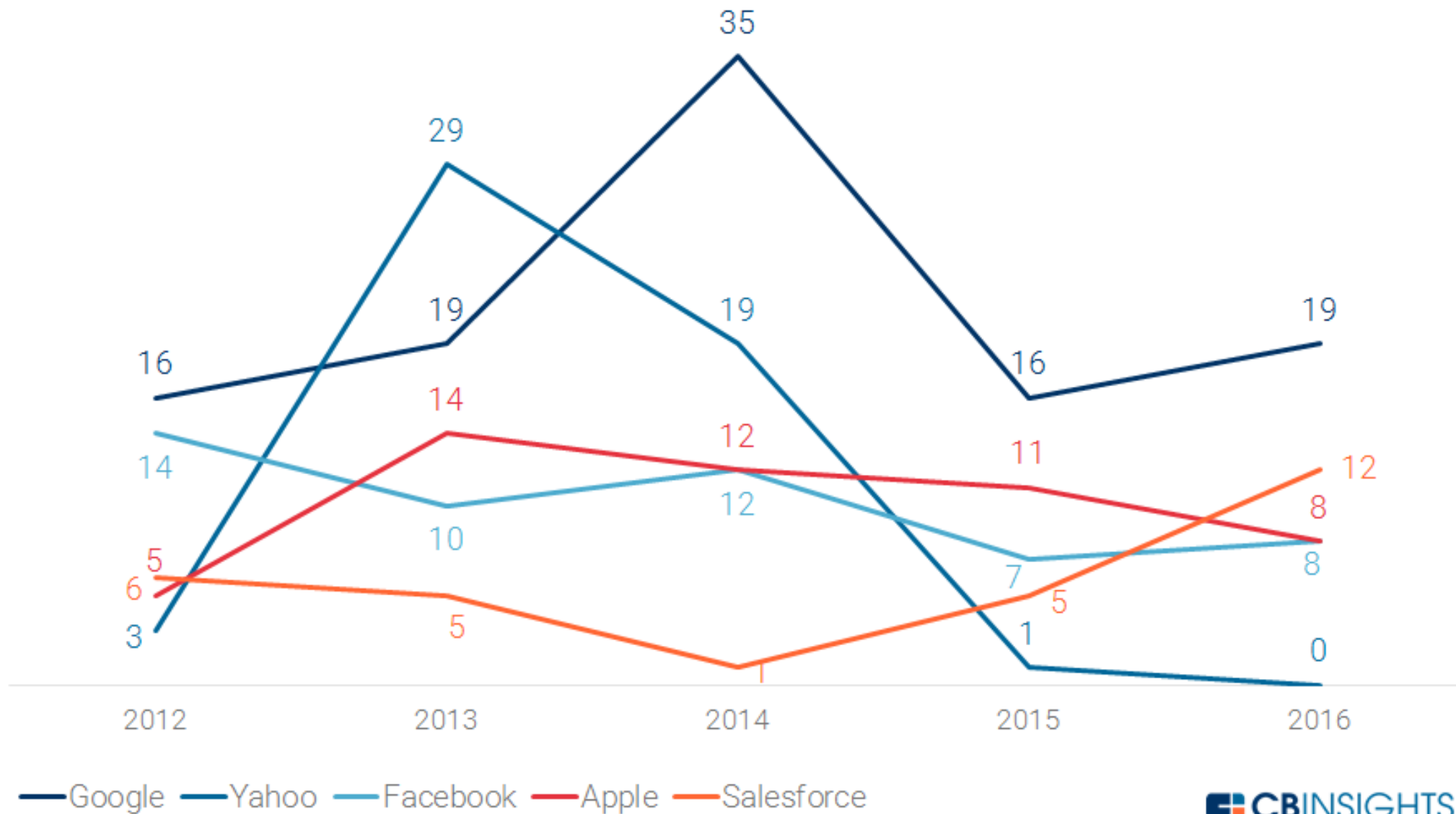

HEDGE FUNDS / MUTUAL FUNDS SLOWED DOWN

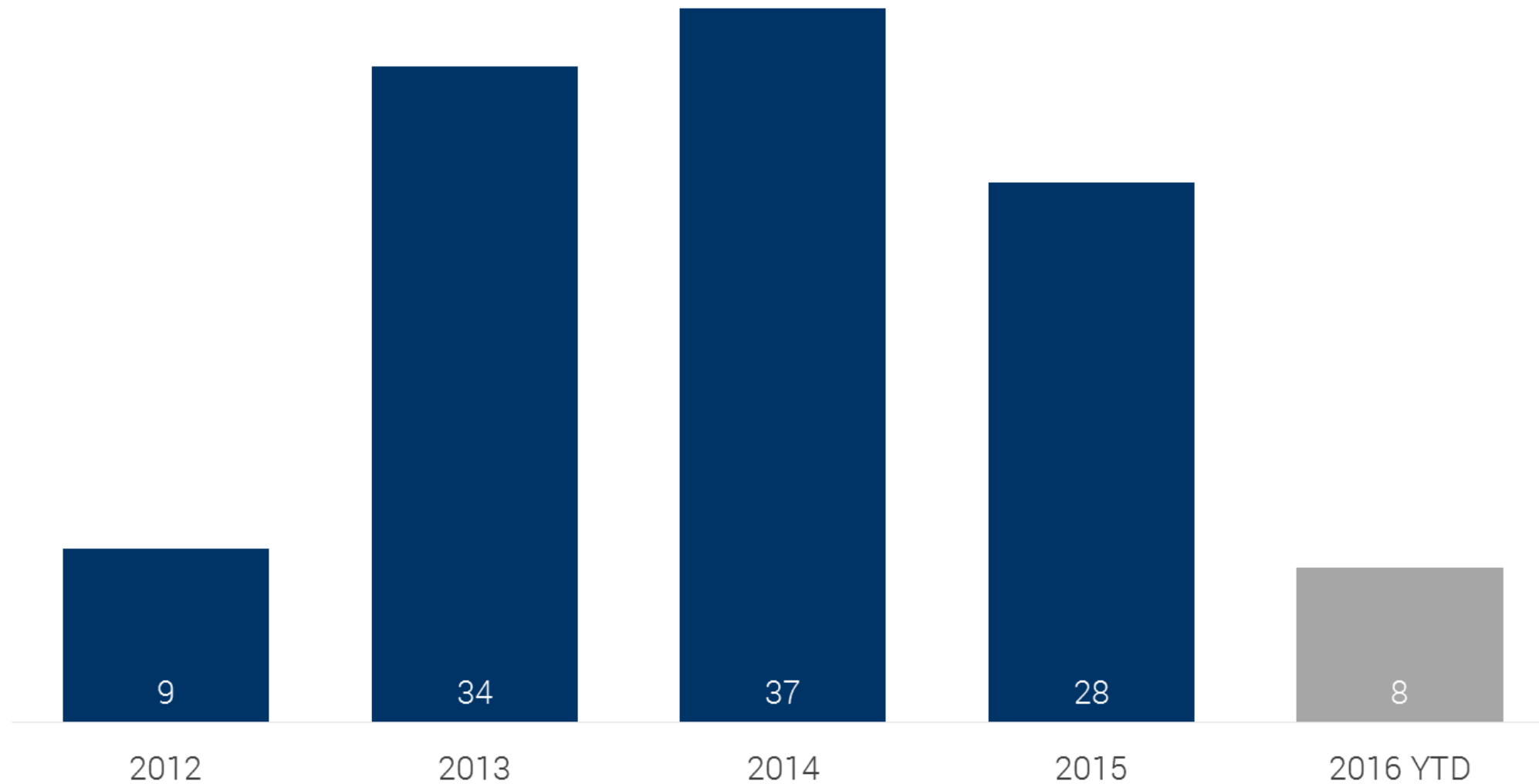



US QUARTERLY VC-BACKED TECH IPO TREND

Q1'14 - Q4'16 (12/19/2016)

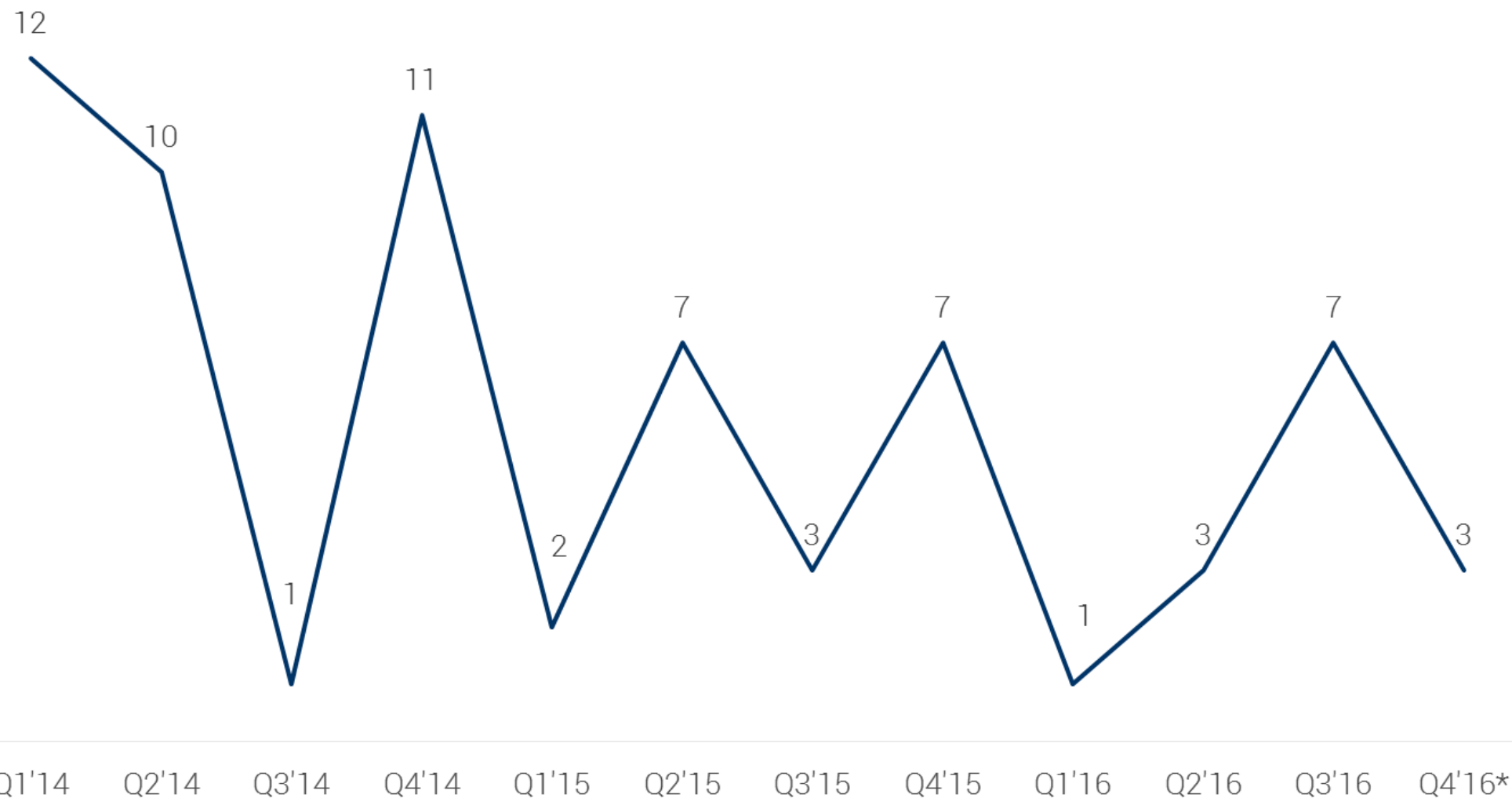

— IPO *Through 12/19/2016

VC-BACKED TECH IPOs REBOUND IN SECOND HALF OF 2016

After registering just four VC-backed tech IPOs in the first half of 2016, the second half of 2016 to date has seen 10 VC-backed tech companies go public including Coupa Software, Nutanix, The Trade Desk, and Apptio.

IN THE HEADLINES

STOCK MARKET'S TERRIBLE START TO
2016 JUST GOT WORSE

February 10, 2016



HISTORIC WEEK: DOW PLUNGES 1,079
POINTS

January 8, 2016



BRITAIN VOTES TO LEAVE E.U.;
CAMERON PLANS TO STEP DOWN

June 23, 2016



PRESIDENTIAL ELECTION ANXIETY
MAY DELAY TECH IPOs

September 2, 2016



TRUMP COULD BE BAD NEWS FOR
TECH IPOs

November 15, 2016





Here's the good news...

ABOUT ME

Anand Sanwal

CEO / Co-founder, CB Insights

Ran American Express \$50M Chairman's Innovation Fund

Prior work in venture capital and M&A

Author of "Optimizing Corporate Portfolio Management" (Wiley 2007)

Graduate of Wharton (Finance/Accounting) and University of Pennsylvania (Chemical Engineering)



@asanwal



asanwal@cbinsights.com



Agriculture Tech

Farmeron M&A
Farmeron is a provider of SaaS solutions for farmers, giving users statistics and actionable production reports to guide farm decision makin...
↳ Virtus Nutrition

6 days ago 1 mention Remind me

OnFarm Systems \$0.13M
OnFarm Systems combines a comprehensive array of leading farm hardware technologies into a single grower-friendly management and decision pl...
- 500 Accelerator

14 days ago 1 mention Remind me

Cogent3D \$1.5M
Cogent3D is the maker of multiple iOS applications like iCropTrak, iGeoTrak, PrecisionEarth, and iGeoBore. The company's solutions have...
- Undisclosed Investors

21 days ago 1 mention Remind me

S4 \$1.20M
S4, previously known as Solapa4, has developed a decision making platform for the agricultural company integrat...
- Cultivation Co

22 days ago 1 mention Remind me

S4 \$0.05M
S4, previously known as Solapa4, has developed a decision making geo-referenced platform for the agricultural producer. The company integrat...
- Arch Grants

Internet of Things

Senseware \$2.09M
Senseware creates a sensory system for surroundings. A modular plug-and-play wireless sensor-based system that helps users expose the myriad...
- Undisclosed Investors

4 days ago 1 mention Remind me

Bitfinder \$6.23M
Bitfinder's portable device and software platform detect airborne and environmental irritants. Awair is a smart device that monitors the air...
- Altos Ventures

4 days ago 1 mention Remind me

Protagonist Therapeutics \$90.00M IPO
Protagonist Therapeutics is a biotechnology company that develops and provides a telehealth solution that leverages Google Glass to help patients with lower...
- Undisclosed Investors

8 days ago 1 mention Remind me

MedMinder Systems \$0.50M
MedMinder Systems provides services that help patients with chronic conditions manage their health. The company's easy-to-use...
- Undisclosed Investors

4 days ago 1 mention Remind me

MATTERNET \$9.48M
Matternet is a 21st century transportation system that will transform the way goods are moved locally. Matternet is creating an automated deliver...
- Undisclosed Investors

Healthcare Exits

Maternal Fetal Medicine of Southwest Florida M&A
Maternal Fetal Medicine is a sub-specialty of obstetrics that focuses on diagnosing, treating and caring for women and unborn babies who are...
↳ MEDNAX

Today 1 mention Remind me

Medpace \$161.00M IPO
Medpace is a global full-service clinical research organization providing Phase I-IV core development services for drug, biologic, and devic...
↳ Public

5 days ago 7 mentions Remind me

Protagonist Therapeutics \$90.00M IPO
Protagonist Therapeutics is a biotechnology company that develops and provides a telehealth solution that leverages Google Glass to help patients with lower...
- Undisclosed Investors

5 days ago 7 mentions Remind me

Forsight Visions M&A
Forsight Visions was founded in January of 2011 as the fifth company to emerge from the...
↳ Allergan

5 days ago 1 mention Remind me

Signature Healthcare Solutions M&A
Signature Healthcare Solutions specializes in acute care hospital medicine and partners with hospitals in the Chicago market.
↳ TeamHealth Holdings

Medical Devices

Pursuit Vascular \$2.08M
Pursuit Vascular is developing a family of single-use products intended to protect patients from life-threatening infections and provide sub...
- Undisclosed Investors

4 days ago 1 mention Remind me

Clear Guide Medical \$0.03M
Clear Guide Medical develops technologies to provide image fusion and Computer-Assisted Instrument Guidance for minimally invasive medical p...
- Undisclosed Investors

4 days ago 1 mention Remind me

Atomo Diagnostics \$3.47M
Atomo Diagnostics is commercializing a range of easy to use rapid diagnostic devices and services that deliver clinical and economic value t...
- Global Health Investment Fund

4 days ago 4 mentions Remind me

Greater Alabama Lithotripsy \$0.32M
Greater Alabama Lithotripsy is a provider of minimally invasive urological services and products.
- Undisclosed Investors

4 days ago 1 mention Remind me

JenaValve Technology \$10.00M
JenaValve Technology develops, manufactures and markets transcatheter aortic valve implantation systems (TAVI) to treat patients suffering f...
- Edmond de Rothschild Investment Partners & 3 others

Payments

Red Dot Payment
Red Dot Payment is a Singapore payment processing company based in Southeast Asia. The company's product...
- GMO VenturePartners & 3 others

4 days ago 1 mention

FC Exchange
FC Exchange is an international and payment company. FCE's services are for businesses and individuals, and f...
↳ Global Reach Partners

4 days ago 2 mentions

Transfert Credit
Transfert Credit provides international top-up services.
↳ Ding

6 days ago 1 mention

Wangyudashi
Wangyudashi, which operates wangyuhudong.com, is a specialist for internet cafe payments and...
- Shenzhen Capital Group Co

6 days ago 3 mentions

Prepaid Technologies Company
Prepaid Technologies combines relationships and payments systems with innovative technology to r...
- Ballast Point Ventures

6 days ago 1 mention

Technology market intelligence for data-driven executives.

CB Insights software lets you predict, discuss and communicate emerging technology trends using data in ways that are beyond human cognition.



Patents



**Angel Investors
and VCs**



Startups



**Government
Grants**



**Media and Niche
Sub-Community Chatter**



**Academic and
Corporate Research**

FINDING SIGNAL

Without data, you're just
another person with an opinion.

OLD SCHOOL

(limited by human cognition)

Google searches
Gut instinct
Guys with MBAs
(pundits aka consultants, analysts)

NEW SCHOOL

(beyond human cognition)

Machine learning
Natural language processing
Topic modeling
Probability driven models

Signals discerned from millions of sources including:

- Venture capital / angel investments
- Startup data
- Patents
- Government grants
- News media
- Social media

TRUSTED BY WORLD'S LEADING COMPANIES

“We use CB Insights to find emerging trends and interesting companies that might signal a **shift in technology** or require us to reallocate resources.”

Beti Cung
Corporate Strategy, Microsoft



“ACCORDING TO CB INSIGHTS...”

From the NY Times to Bloomberg, CB Insights data is used by hundreds of leading media outlets every week

CB INSIGHTS MEDIA CITATIONS PER YEAR

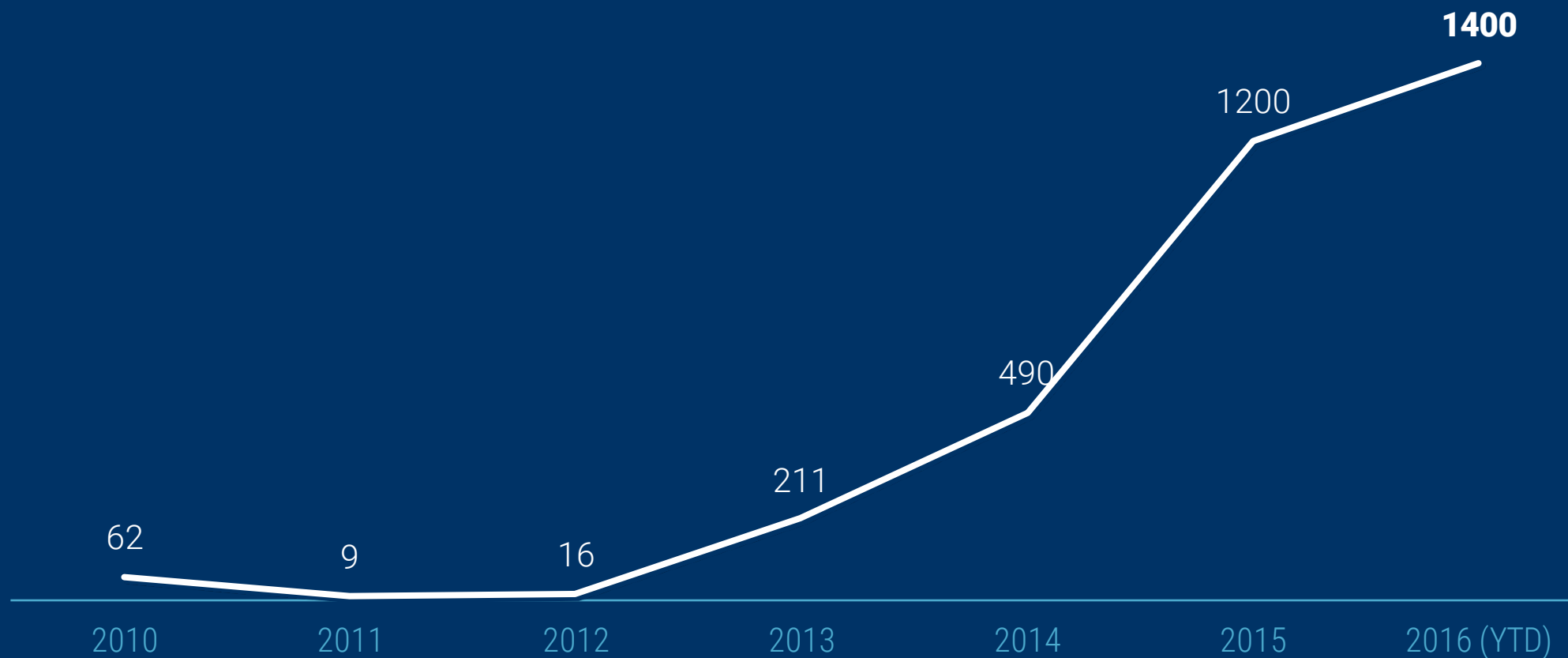

The New York Times 

THE WALL STREET JOURNAL.

Bloomberg  

San Francisco Chronicle

TechFlash  Los Angeles Times

DealB%k  

Forbes 

The Philadelphia Inquirer

 FORTUNE

 REUTERS 

GIGAOM  FASTCOMPANY

readwrite  



Here's the good news...

WHY 2017 WILL BE A GOOD YEAR

- *Repatriation of money from overseas*
- Healthy IPO pipeline
- Lots of money still rushing into startups (corp & foreign)
- Innovation is broad-based across multiple areas
- Competitive lines being redrawn. Chaos creates uncertainty.
- Corporations are outsourcing R&D to startups

A SELECTION OF 2017 TECH IPO PIPELINE COMPANIES



ContextMedia
Health

chewy.com

**SMS
ASSIST**

INSIDESALES.COM



yext

zuora

kCura®

App Annie



DATADOG



TANIUM™



**Blue
Apron**



Thumbtack

credit karma

actifio

REDFIN



CLOUDFLARE®

APPDYNAMICS

**CARBON
BLACK**

 **Age of Learning**

okta

TRADESHIFT®



PLURALSIGHT



MuleSoft®



UNUSUAL SUSPECTS **FOREIGN & CORPORATE MONEY UP**

NUMBER OF CORPORATE VC'S CLIMBING

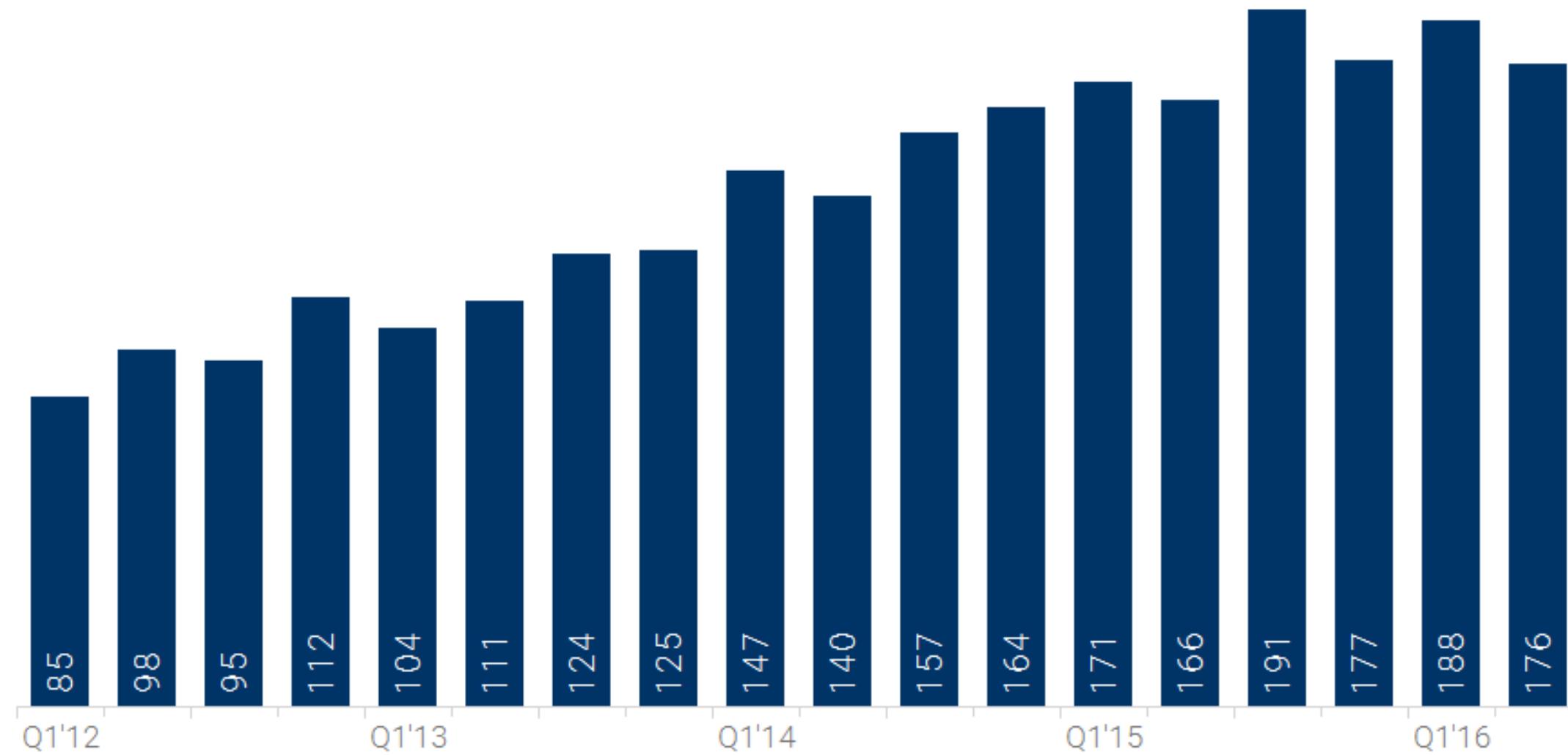

■ Unique CVC Investors

 CBINSIGHTS

STARTUP EMIRATES: UAE AS STARTUP HUB

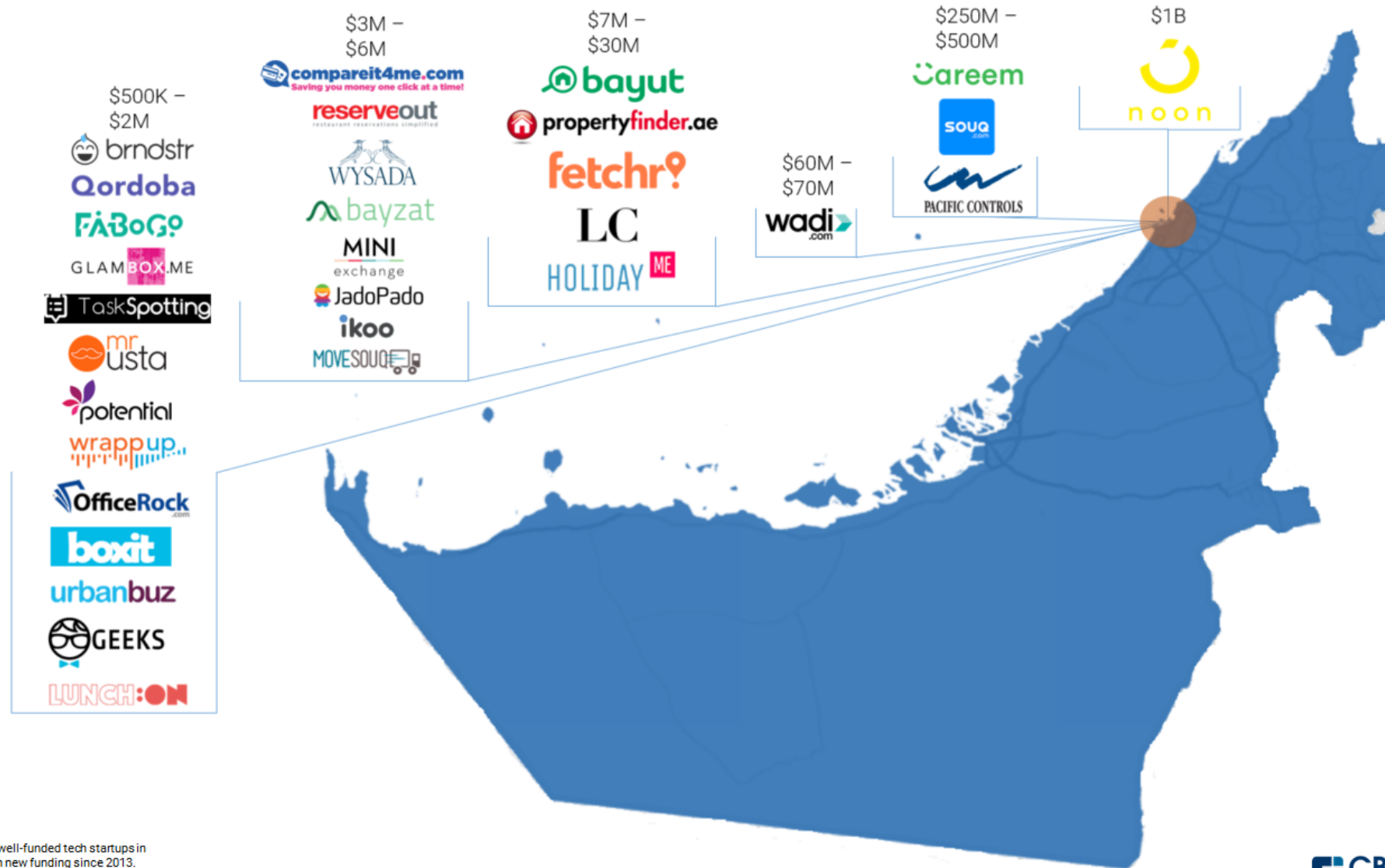

* The most well-funded tech startups in the UAE with new funding since 2013. Companies included raised \$500K+.

1/4 OF US UNICORNS HAVE CHINA INVESTOR

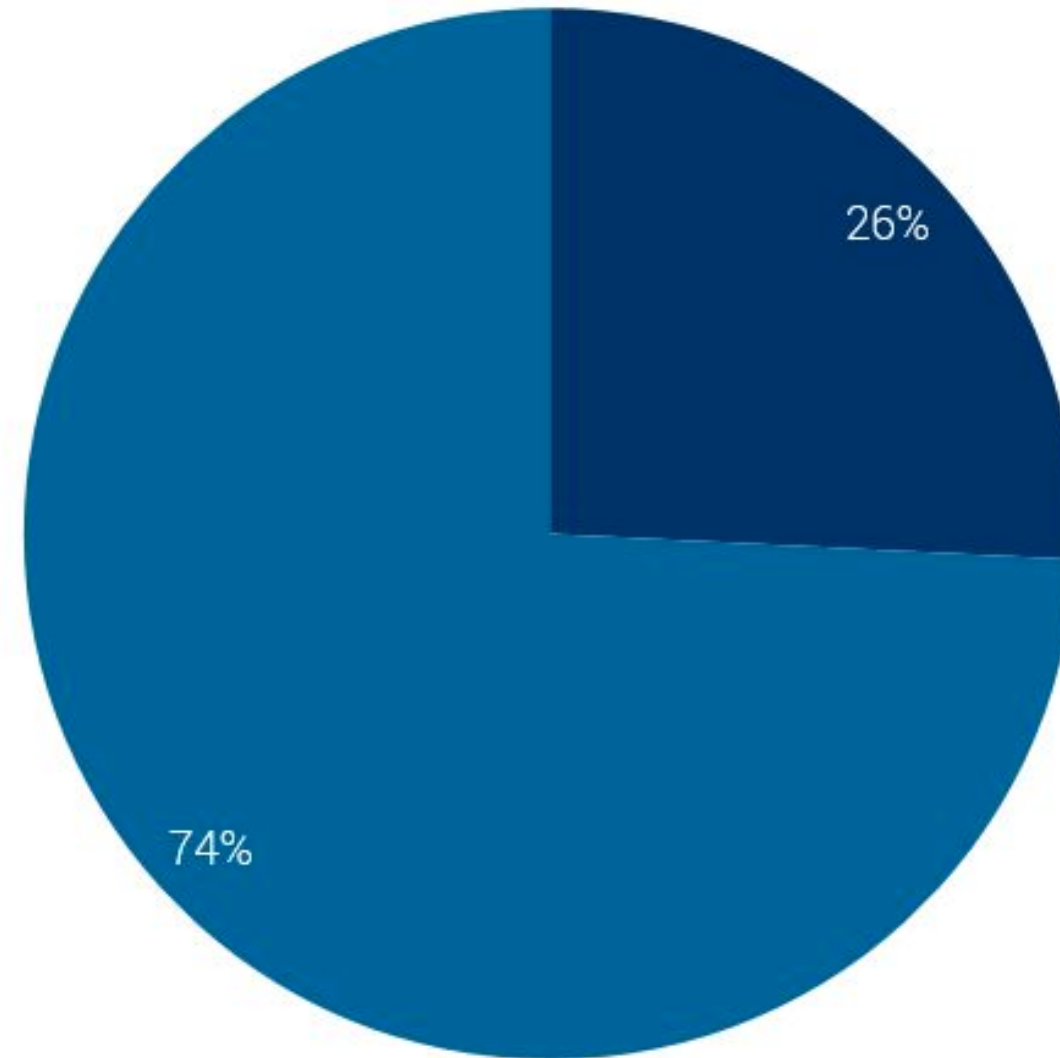

- U.S. Unicorns with a Greater China investor
- All Other U.S. Unicorns

SOFTBANK INVESTED \$4.4B IN LAST 7 YRS

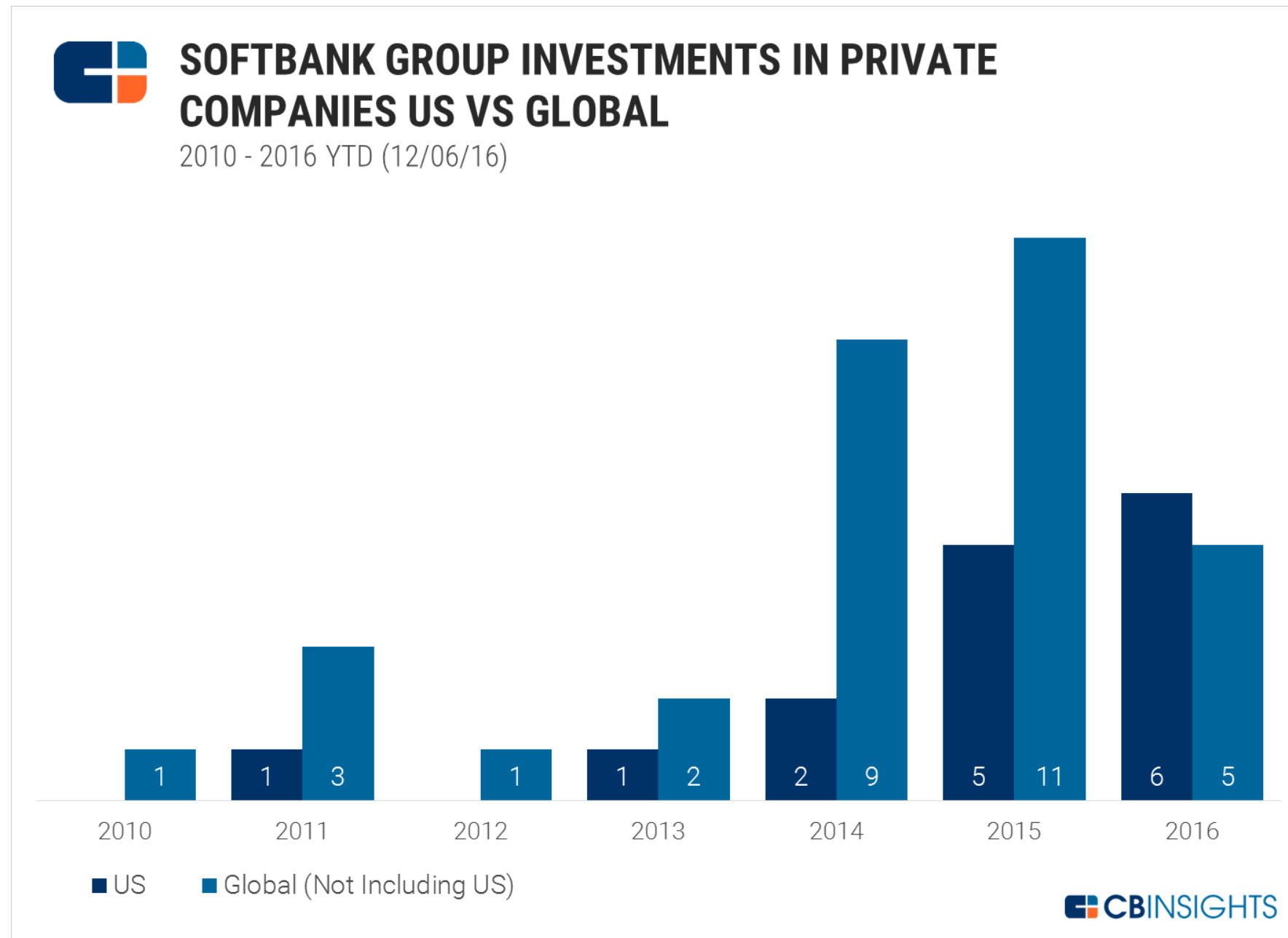



NOT AN ECOMMERCE BOOM
BROAD-BASED TECHNOLOGY SHIFTS

MATTRESS2.0 – SMELL THE DISRUPTION

A Timeline of Mattress Startup First Fundings

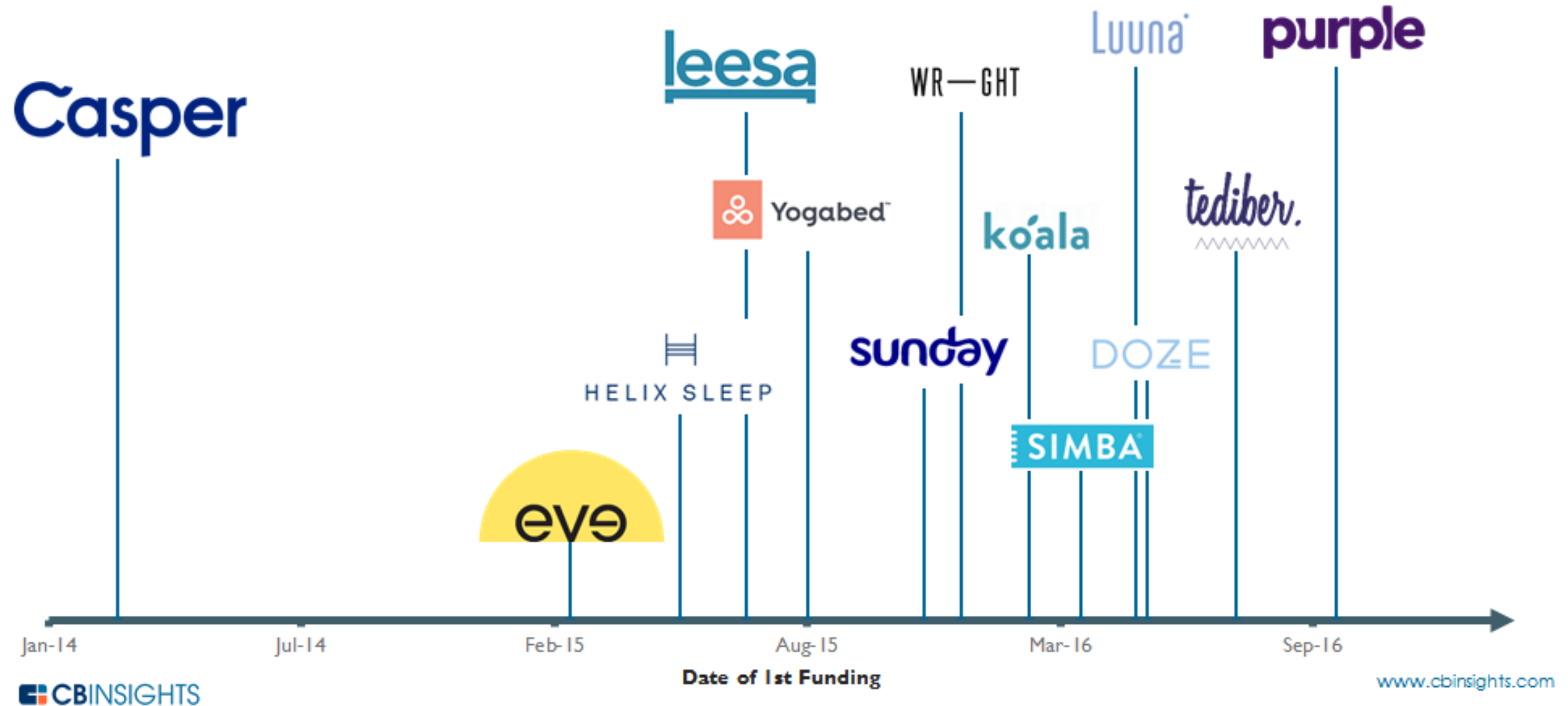

MONEY POURING INTO AR/VR

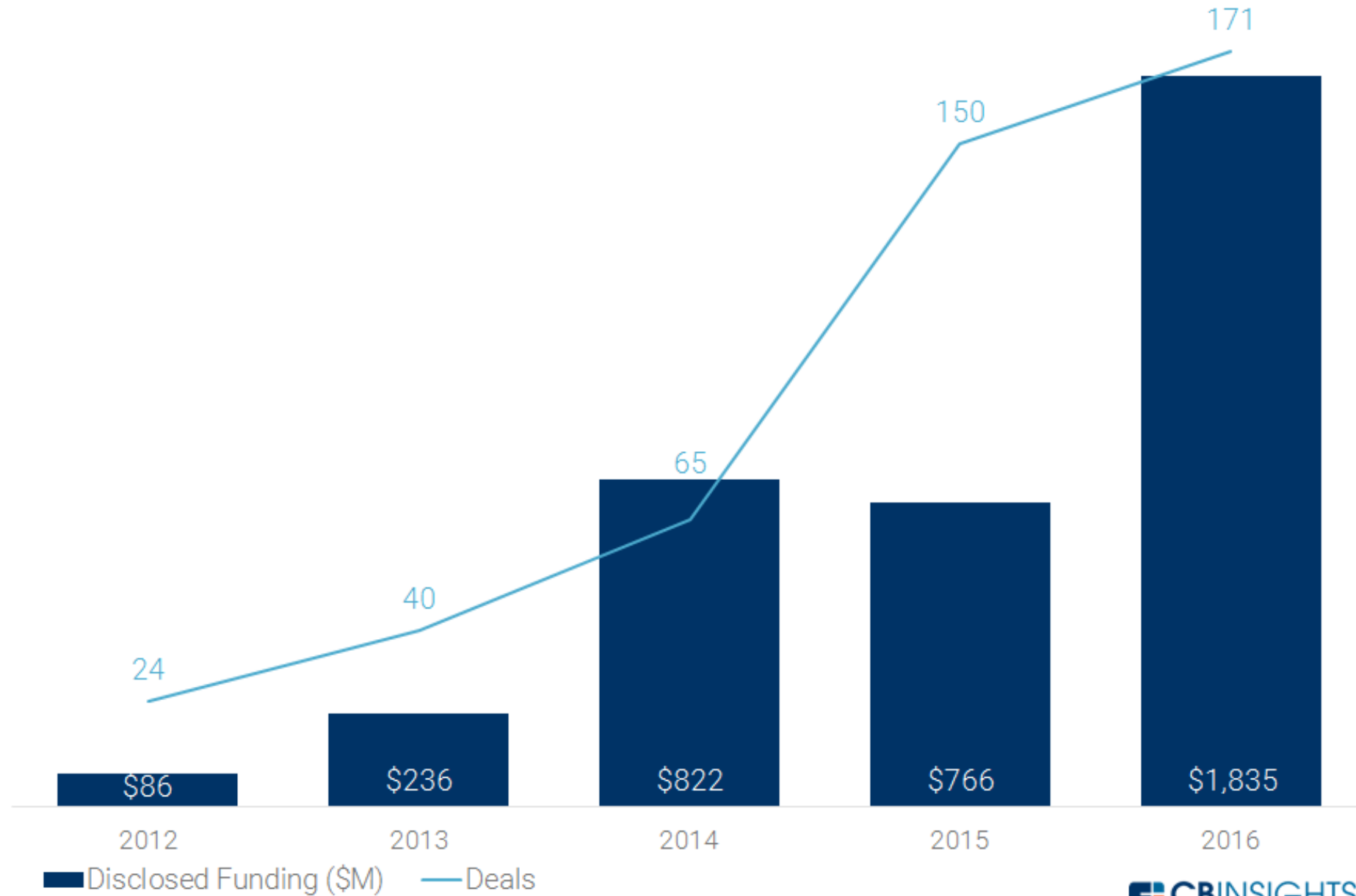

THE ROBOTS ARE COMING



GLOBAL ROBOTICS DEALS DISTRIBUTION

2012-2016

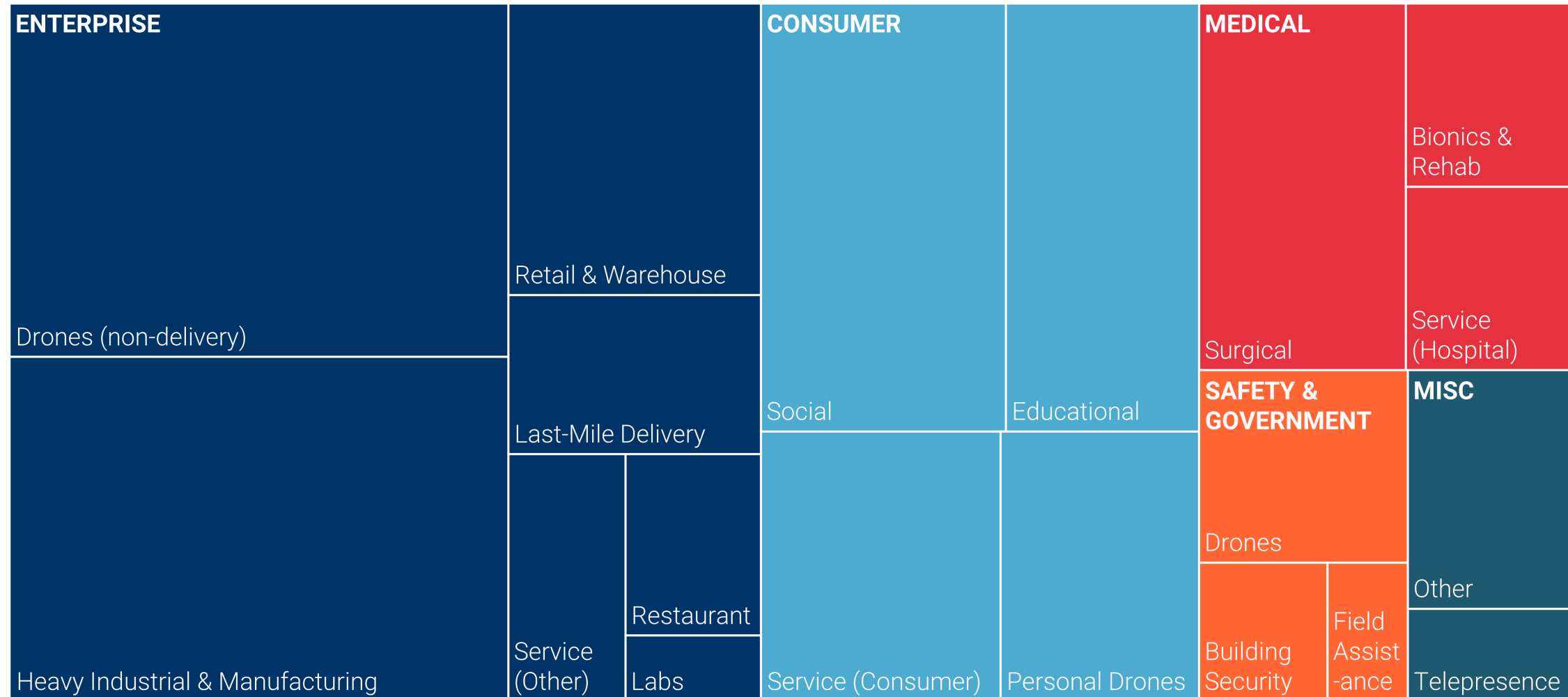

■ MEDICAL ■ ENTERPRISE ■ CONSUMER ■ SAFETY & GOVERNMENT ■ MISC



MEDIA M&A PICKS UP IN FACE OF CHANGE



MEDIA GIANT M&A TIMELINE

2013-2016

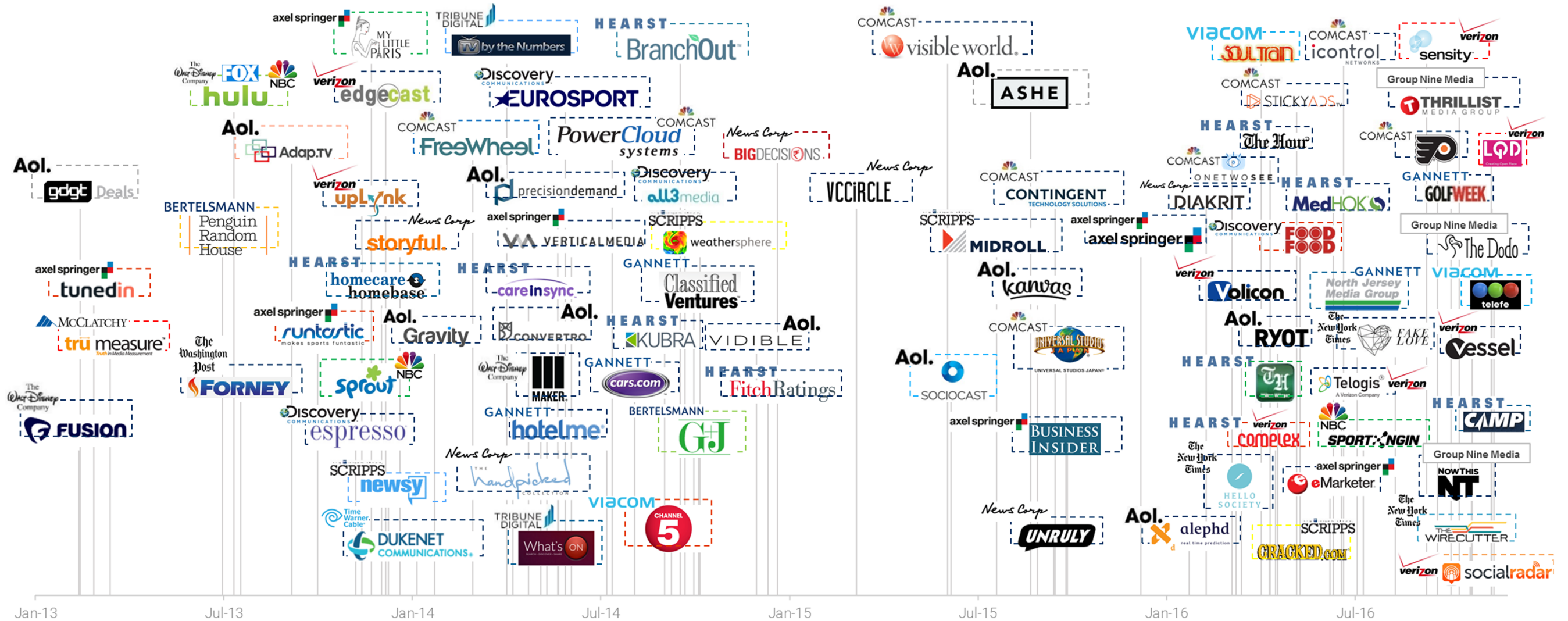

STARTUPS ATTACK MORTGAGE MARKET

MORTGAGE TECH MARKET MAP

MORTGAGE PROCESSING/WORKFLOW SOFTWARE



ANALYTICS



DIGITAL MORTGAGE LENDING



MARKETPLACE LENDING



DIGITAL MORTGAGE BROKER

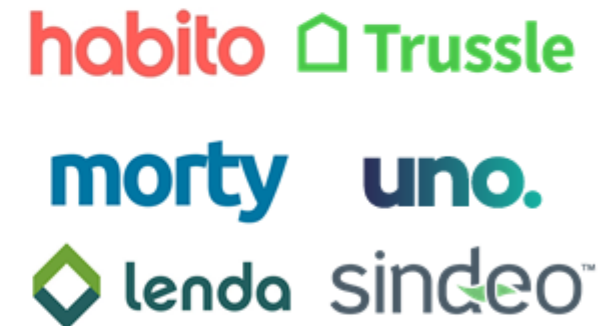

MORTGAGE AUCTION SITE



 CBINSIGHTS

QUANTUM COMPUTING IS SEEING BIG MONEY

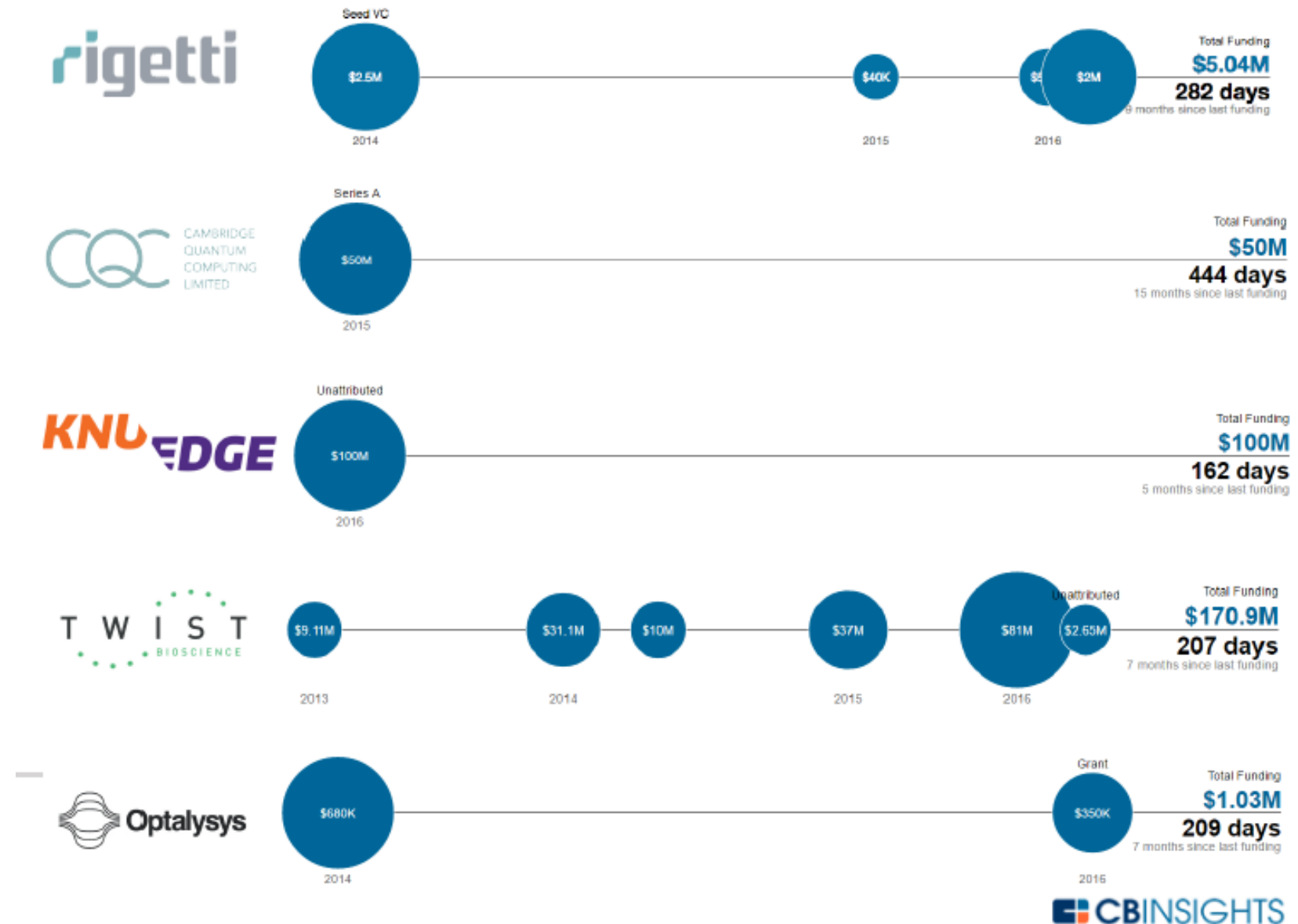

THE UNITED STATES OF CANNABIS: FIRST EQUITY ROUNDS TO PRIVATE COMPANIES

2014-2016

WASHINGTON

MINNESOTA

COLORADO

OREGON

NEVADA

CALIFORNIA

ARIZONA

KANSAS

NEW MEXICO

ILLINOIS

PENNSYLVANIA

NEW HAMPSHIRE

CONNECTICUT

DELAWARE

MASSACHUSETTS

NEW YORK

WASHINGTON D.C.

GEORGIA

FLORIDA

MARYLAND

HAWAII

Startups working in mobility secured

\$13.8 BILLION

across

212 DEALS

in 2016

INVESTORS & STARTUPS ARE TARGETING OPPORTUNITIES ACROSS THE SPECTRUM

ELECTRIC VEHICLE TECH

\$2.1B, 51 Deals



AUTO TECH

\$1B, 87 Deals



RIDE-SHARING/-HAILING

\$10.7B, 55 Deals



Examples are illustrative and not exhaustive. Financing figures are full-year 2016.

INCUMBENTS ARE PARTNERING WITH UPSTARTS TO COMPLETE THE STACK

ELECTRIC VEHICLE TECH

AUTO TECH

RIDE-SHARING/-HAILING



Examples are illustrative and not exhaustive. Financing figures are full-year 2016.

2016 WAS AN INFLECTION POINT IN HYPE

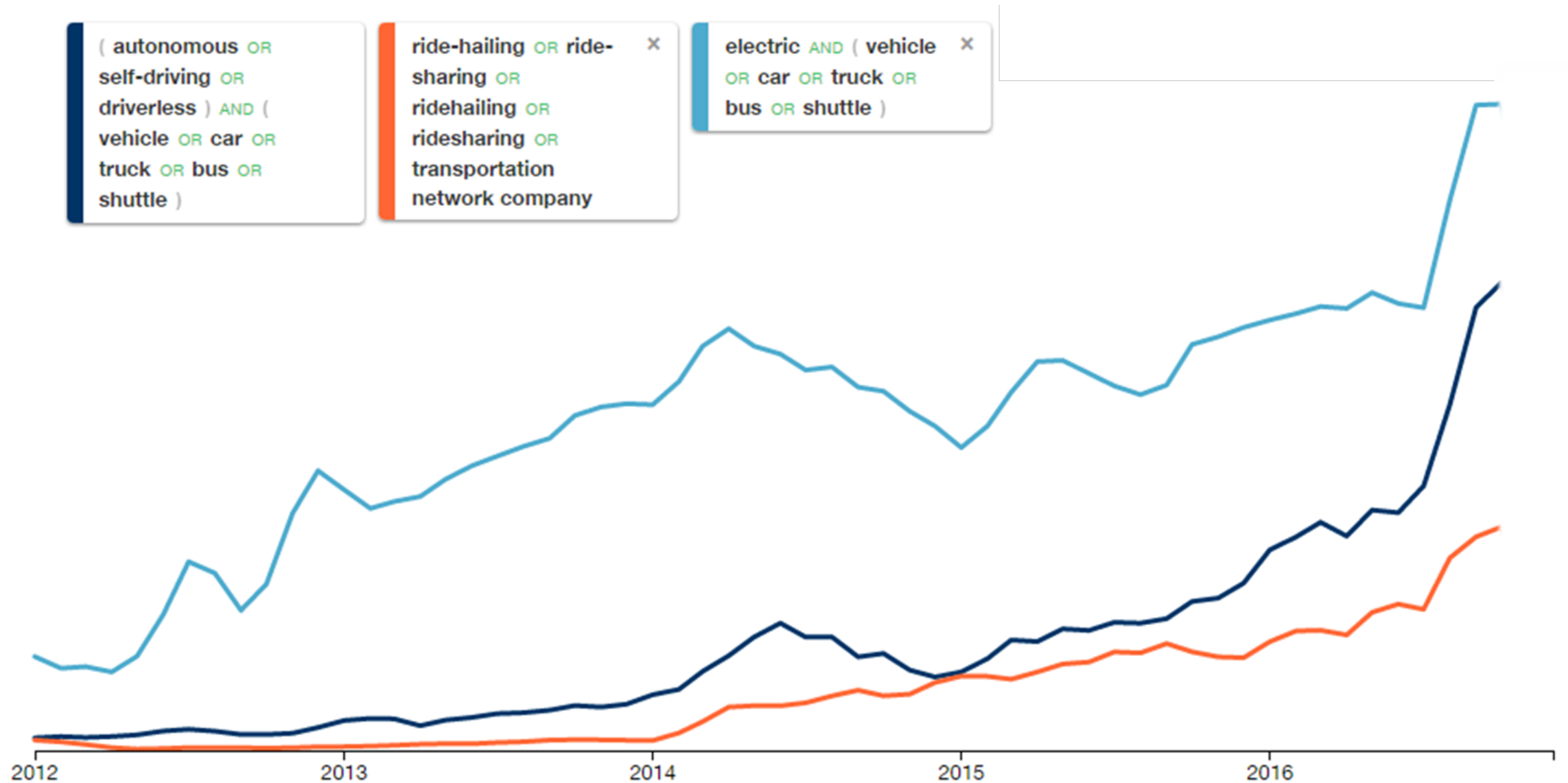

DRAWING A BEVY OF INVESTORS

ACCELERATORS



GENERALIST VCS



MOBILITY-FOCUSED VCS



CORPORATE VCS



CORPORATIONS



Investor group is illustrative and not exhaustive



BIG AUTO'S MOVES IN AUTO TECH AND RIDE-HAILING

Major tech partnerships, investments, and acquisitions

AS MAJOR AUTOMAKERS SCRAMBLE TO RESPOND

Faced with incursions on multiple fronts, incumbent automotive OEMs are frantically investing, acquiring, and partnering to bridge technology gaps.

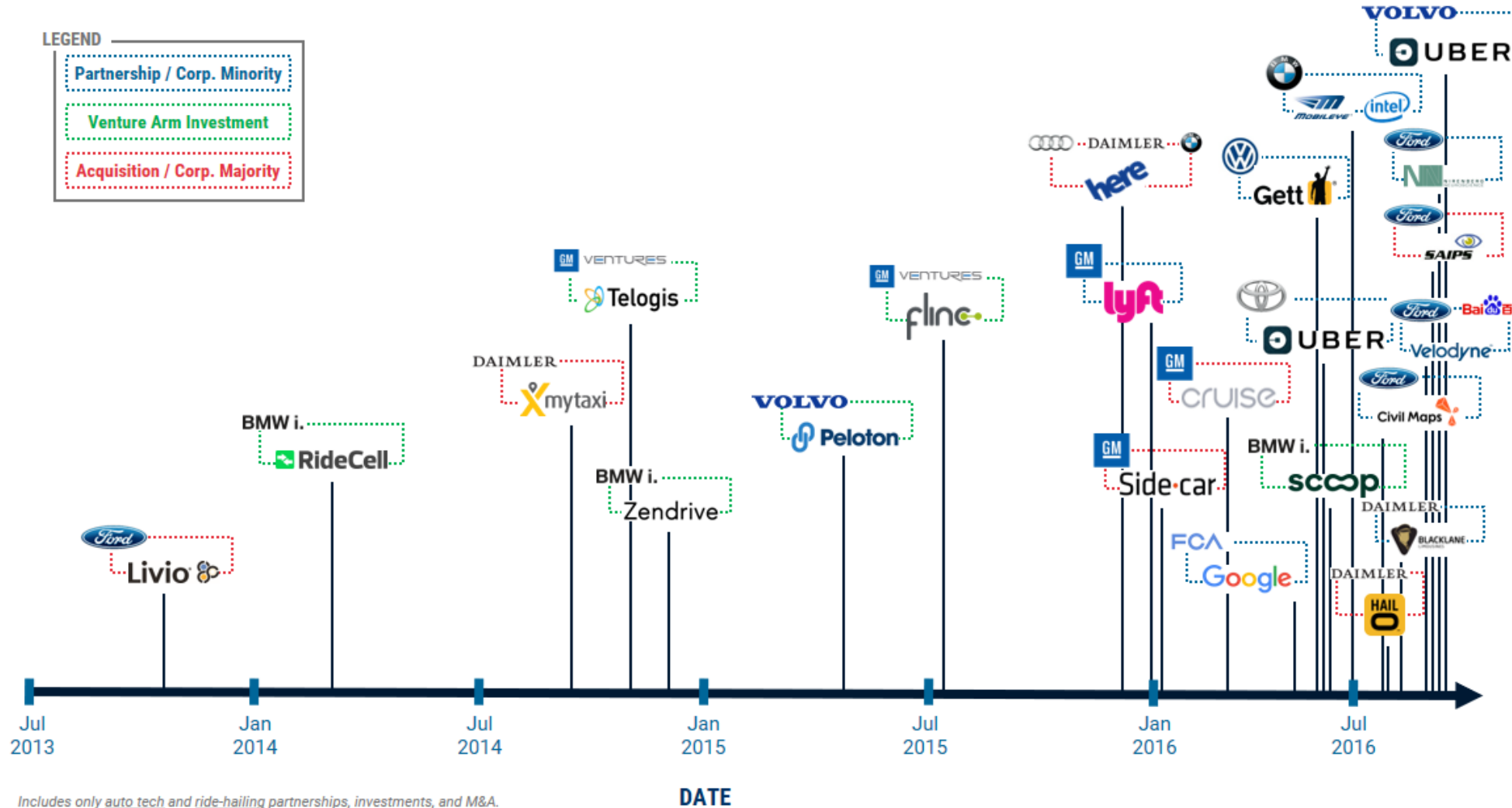

Includes only auto tech and ride-hailing partnerships, investments, and M&A. Investments mark date of first investment for a corporation/CVC.



THE AUTONOMOUS ECOSYSTEM TOOK OFF...

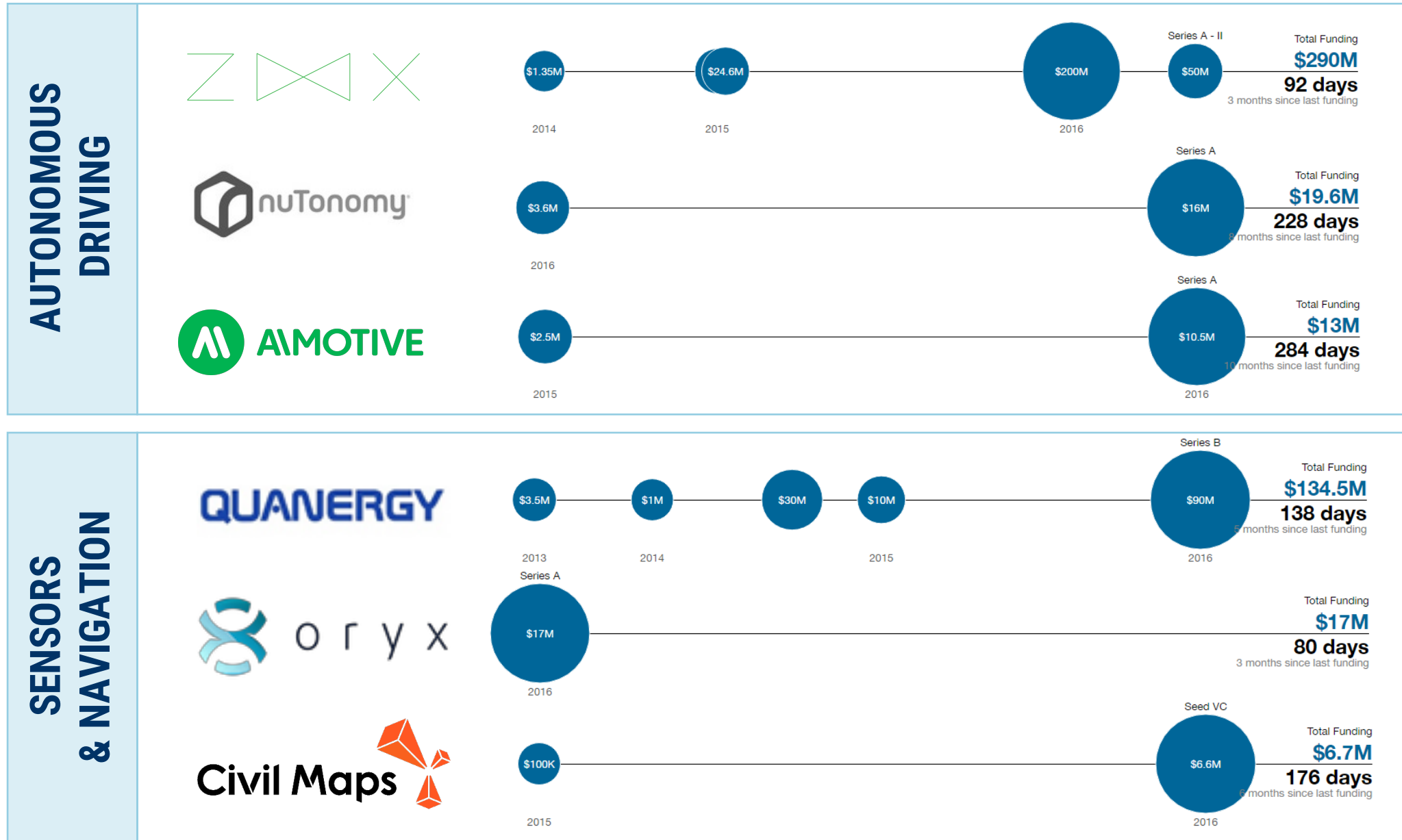

...and many more

Examples are illustrative and not exhaustive

AND MARRIAGES TO RIDE-SHARING BEGAN

Grab Joins nuTonomy to Offer Self-Driving Taxis in Singapore



GM, Lyft to Test Self-Driving Electric Taxis



Pittsburgh, your Self-Driving Uber is arriving now

THESE TRENDS ARE ALSO COMING TO TRUCKING..

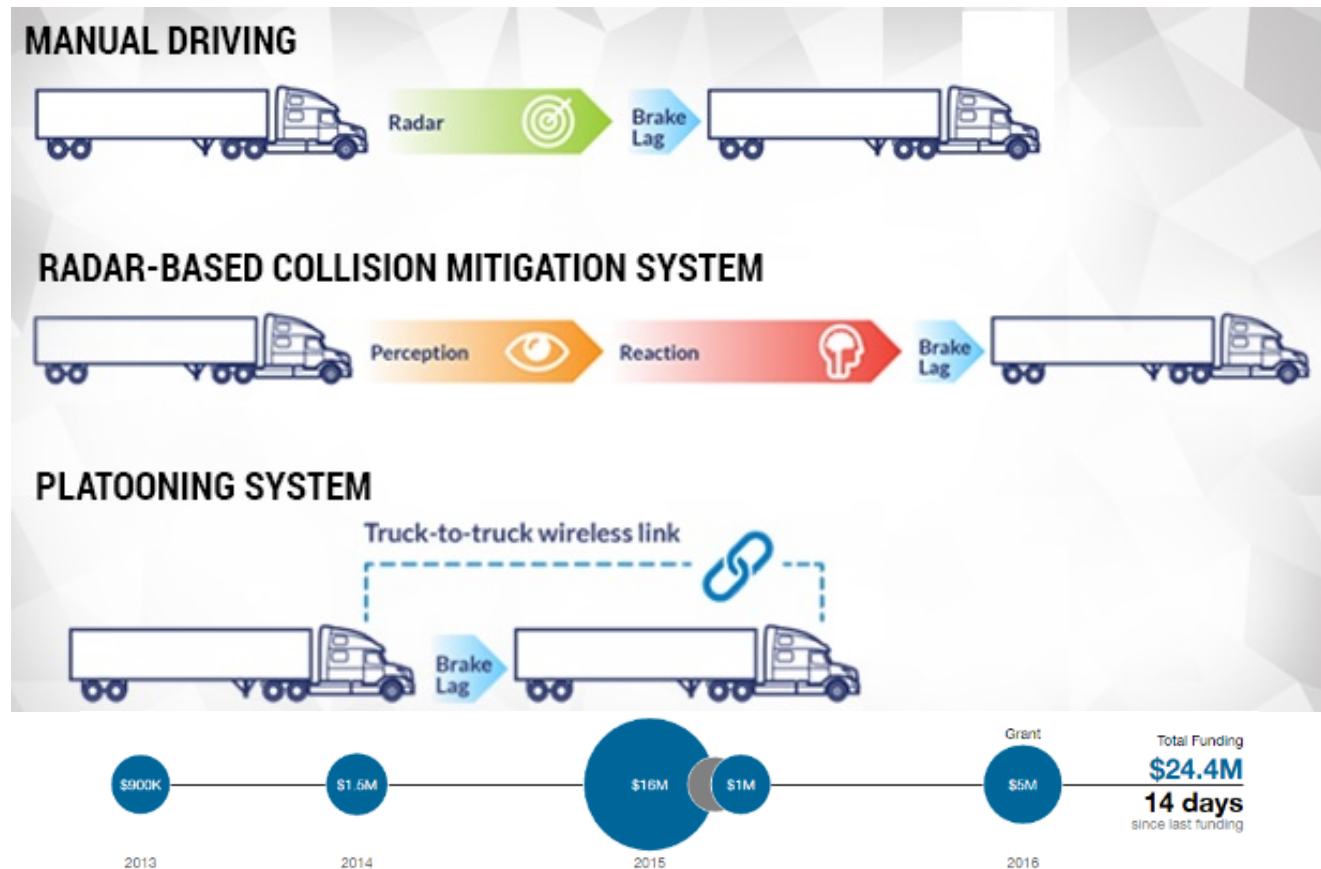

Uber acquires autonomous truck startup Otto, co-founder to lead self-driving efforts

ALL THE WAY DOWN TO LAST-MILE DELIVERY

 **STARSHIP**



dispatch
making delivery smart



Flirtey



 **MATERNET**



A network diagram background consisting of numerous small grey dots connected by thin grey lines, forming a complex web of connections. The dots are of varying sizes and are distributed across the entire blue background. The lines are thin and connect the dots in a non-uniform, organic pattern.

INSURANCE TECH BOOMS

SQUARETRADE'S \$1.4B ACQUISITION PUTS MORE FOCUS ON INSURANCE TECH

TOP VENTURE-BACKED INSURANCE EXITS 2010 - 2016 YTD (11/30/2016)

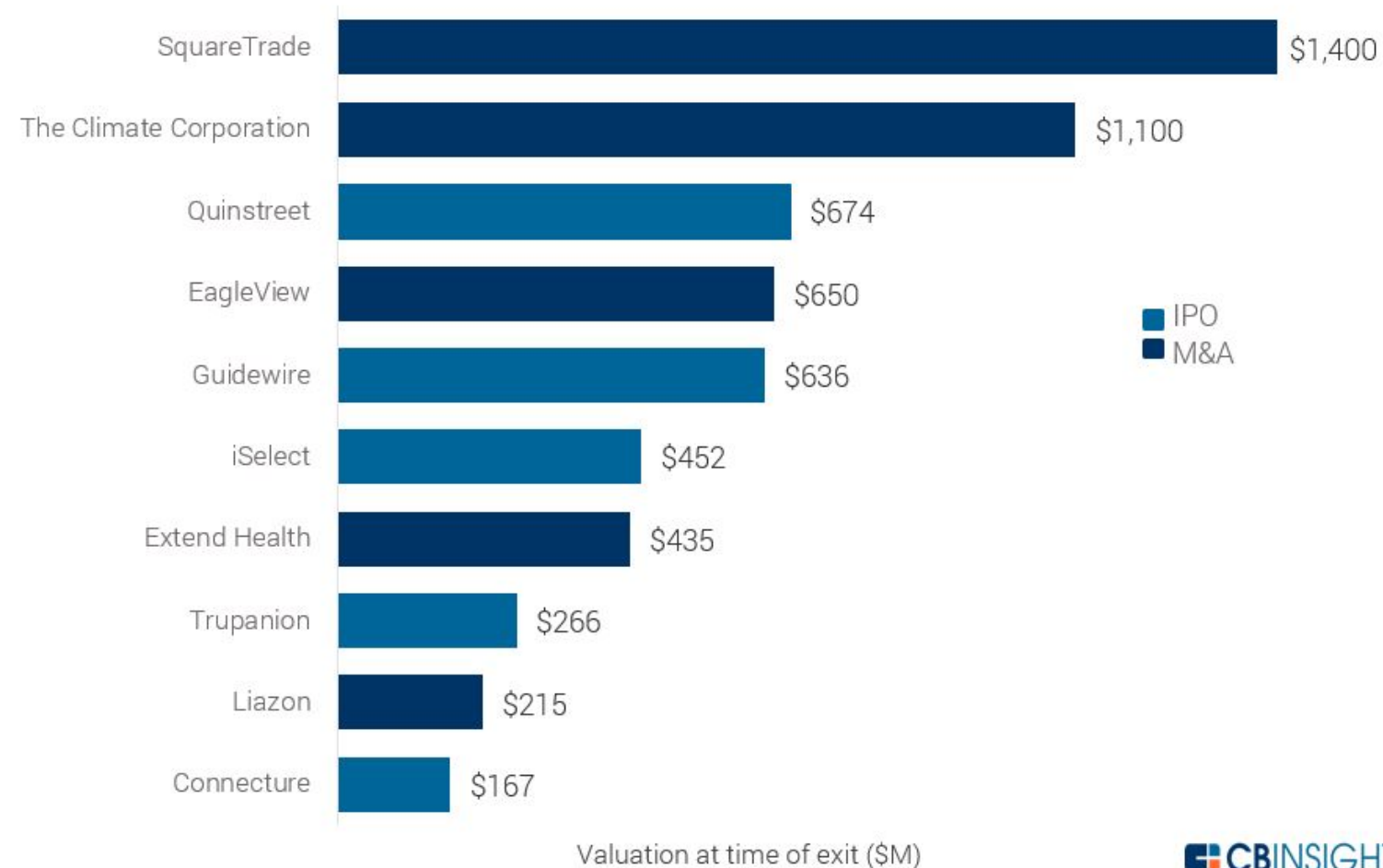

Source: [CB Insights](#)

Insurance Tech: 2016 Startup Landscape

DIGITAL DISTRIBUTION

Lemonade™
trōv
metromile
Slice

MORE COMPLEX LINES

Ladder
EMBROKER
next insurance
Fabric

AI AND MACHINE LEARNING

CYENCE
CAPE ANALYTICS
DataRobot
Captricity

INSURANCE TECH STARTUP INVESTMENT DEALS HIT A NEW HIGH IN 2016

 **INSURANCE TECH ANNUAL FINANCING TREND**
2011 - 2016

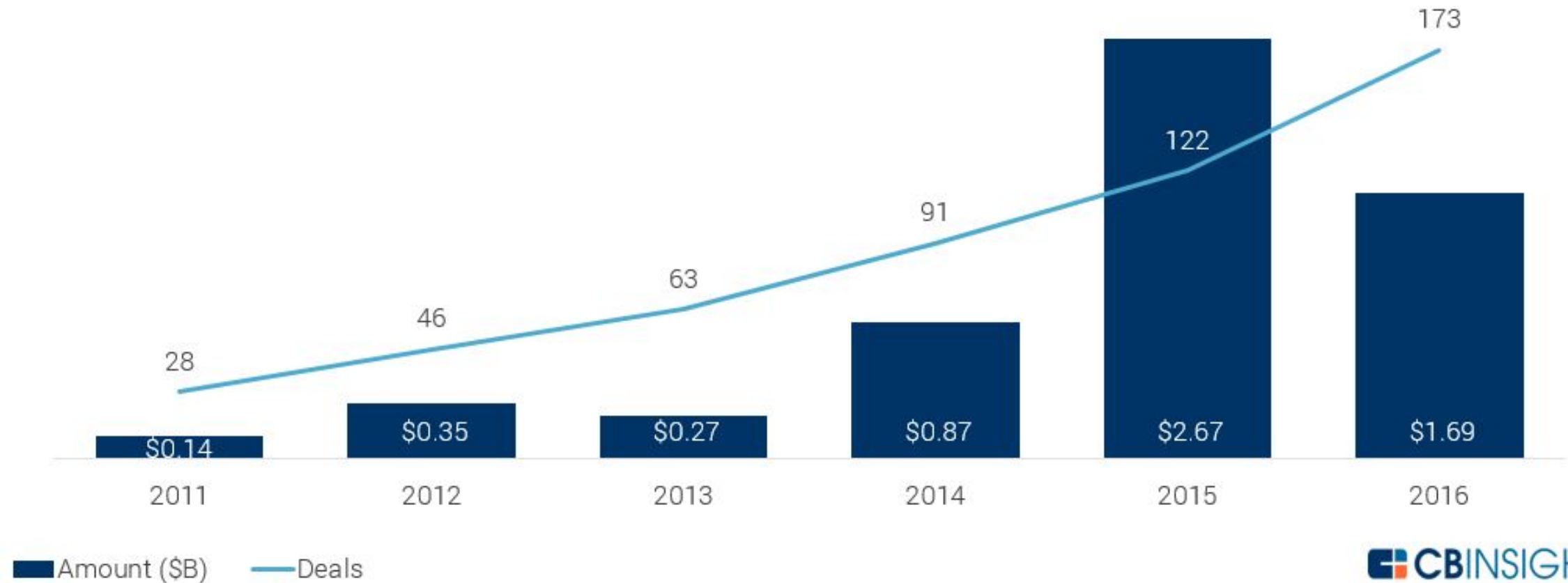

2 OF EVERY 3 INSURANCE TECH DEALS IN 2016 WENT TO EARLY-STAGE STARTUPS

EARLY-STAGE INSURANCE TECH FINANCING TREND
Seed / Series A, 2011 - 2016

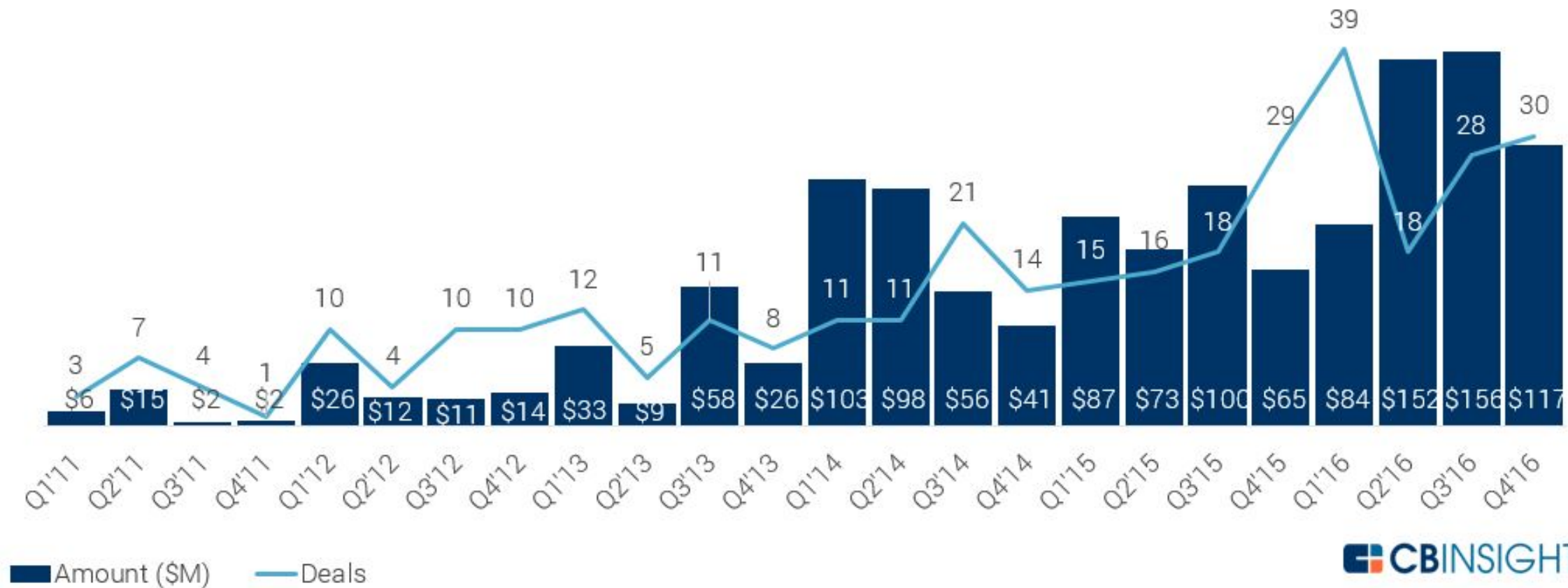

Source: [CB Insights](http://www.cbinsights.com)

STARTUPS GOING AFTER MORE COMPLEX LINES

Commercial insurance, or insurance sold to companies and corporations, was one of the most active areas for insurance tech startup formation and investment in 2016, especially in the small business segment.

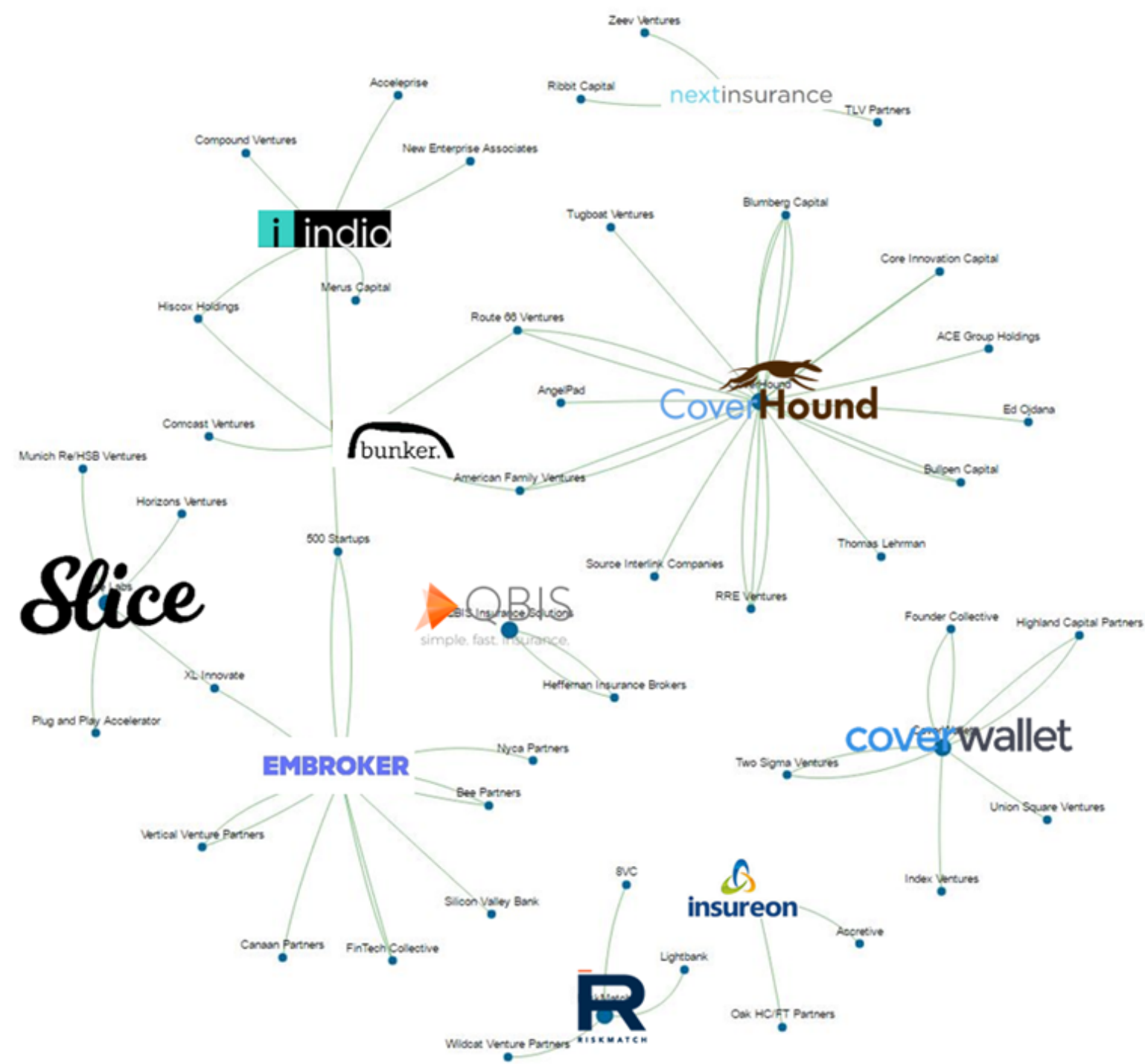

The background features a complex network diagram with numerous nodes and connecting lines, overlaid on a pattern of overlapping circles. The entire scene is set against a dark blue gradient background.

HEALTHCARE AND AI

AI HELPS MAKE SENSE OF THE HEALTH DATA



ARTIFICIAL INTELLIGENCE: CATEGORY HEATMAP

2011-2016 (as of 7/7/2016)

CATEGORY	2011	2012	2013	2014	2015	2016YTD
Healthcare	Light Green	Light Orange	Light Orange	Light Red	Dark Red	Dark Red
Advertising, Sales & Marketing	Light Orange	Light Orange	Light Red	Light Red	Dark Red	Light Orange
Core AI	Light Green	Light Orange	Light Orange	Dark Red	Light Red	Light Orange
Business Intelligence	Light Green	Light Orange	Light Orange	Light Red	Dark Red	Light Orange
Security	Light Green	Light Blue	Light Green	Light Orange	Light Red	Light Orange
Finance	Light Blue	Light Green	Light Green	Light Orange	Light Orange	Light Orange
IoT/Wearables	Light Blue	Light Blue	Light Orange	Light Orange	Light Red	Light Orange
Customer Relationship Management	Light Blue	Light Blue	Light Blue	Light Green	Light Green	Light Orange
Personal Assistant/Productivity	Light Blue	Light Blue	Light Green	Light Blue	Light Green	Light Orange
Education	Light Blue	Light Green	Light Green	Light Blue	Light Green	Light Blue

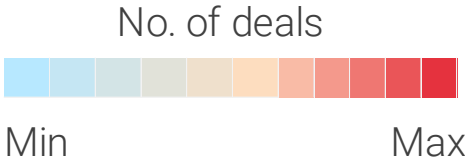

INTEREST IN THE AREA HAS SPIKED

● healthcare AND artificial intelligence

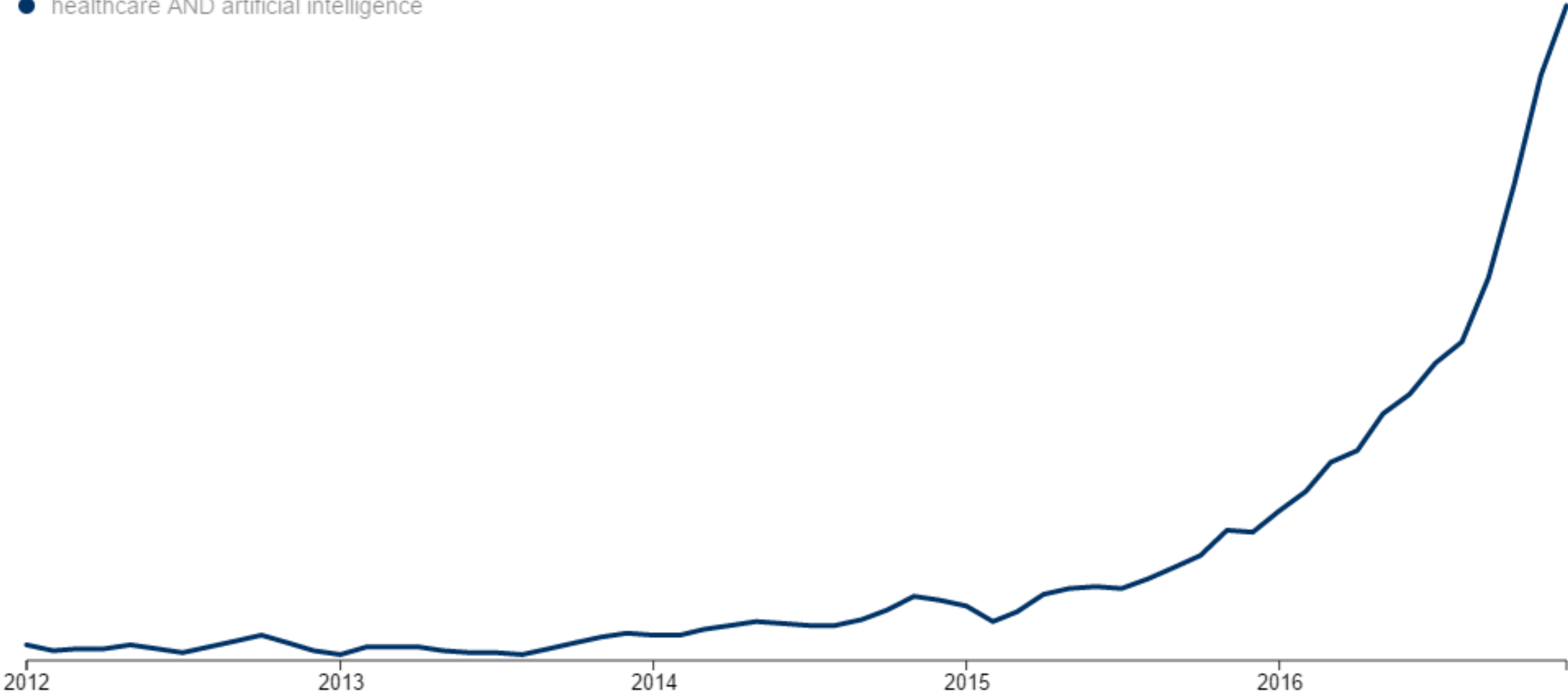

AI-DRIVEN MEDICINE

DIAGNOSTICS

DRUG DISCOVERY

APPLIED GENOMICS

AUTOMATED CARE + TRIAGING





x



x

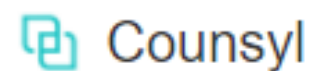

x

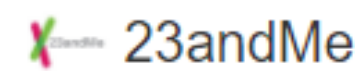

x

Headquarters	Palo Alto California United States	Burlingame California United States	South San Francisco California United States	Mountain View California United States
Website	freenome.com	getcolor.com	counsyl.com	23andme.com
VC Backed	Yes	Yes	Yes	Yes
# of Investors	9	16	12	17
Days Since Last Funding	209	129	973	84
Total Funding	\$7.05M	\$60M	\$88.2M	\$244.05M

APPLIED GENOMICS

Companies trying to understand the relationship between genes and our health so we can be more proactive about it.

GRANULAR DATA ON INDIVIDUALS ALLOWS FOR HIGHLY TARGETED THERAPIES

CRISPR COMPANIES

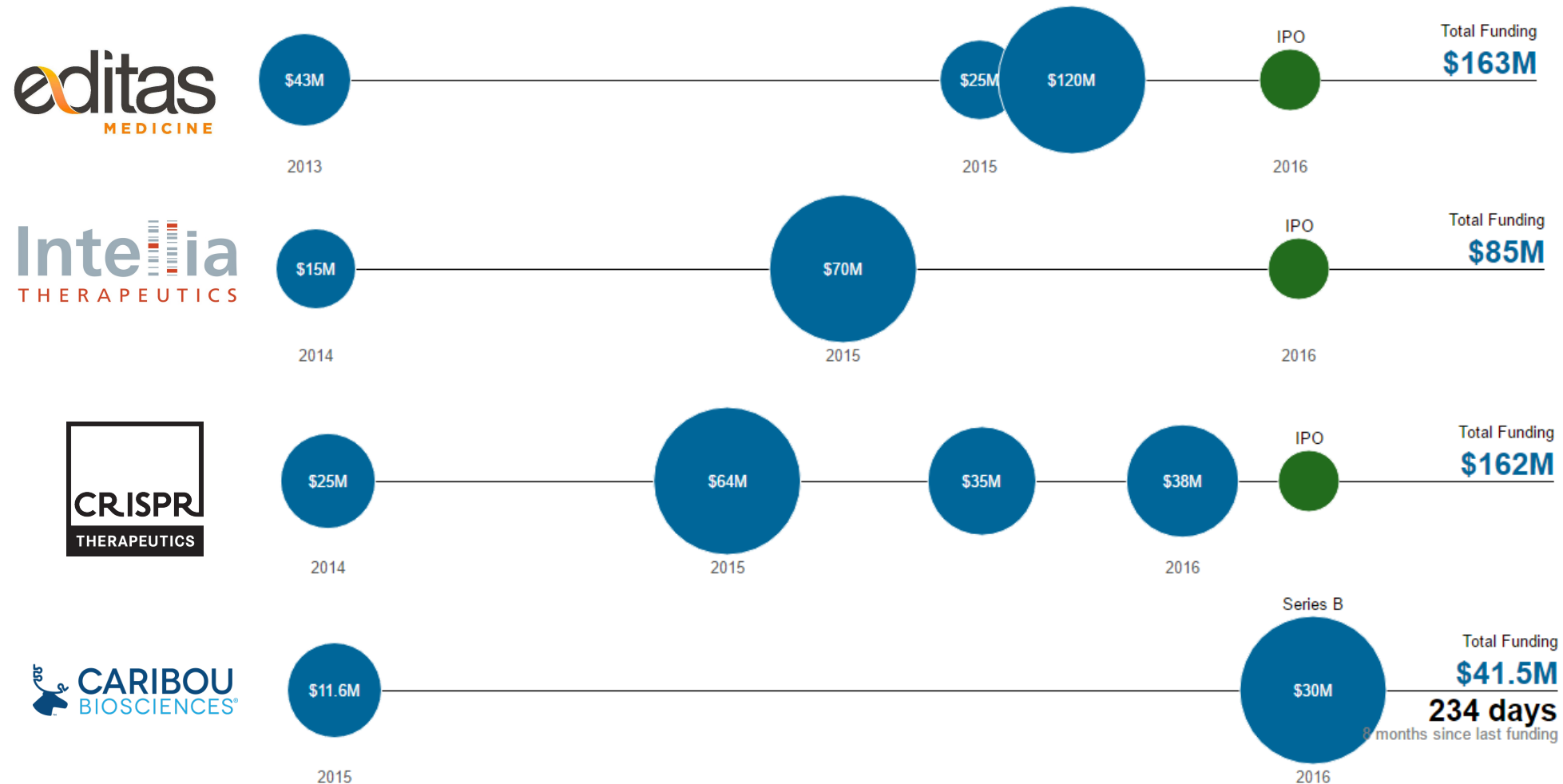

AS WELL AS MORE INDIVIDUALIZED MEDICATIONS

FDA Approved 3D Printed Drug Available In The US



DATA SAFETY IN HEALTHCARE CREATES OPPS

2015 Healthcare Breaches

Number of Individuals Breached

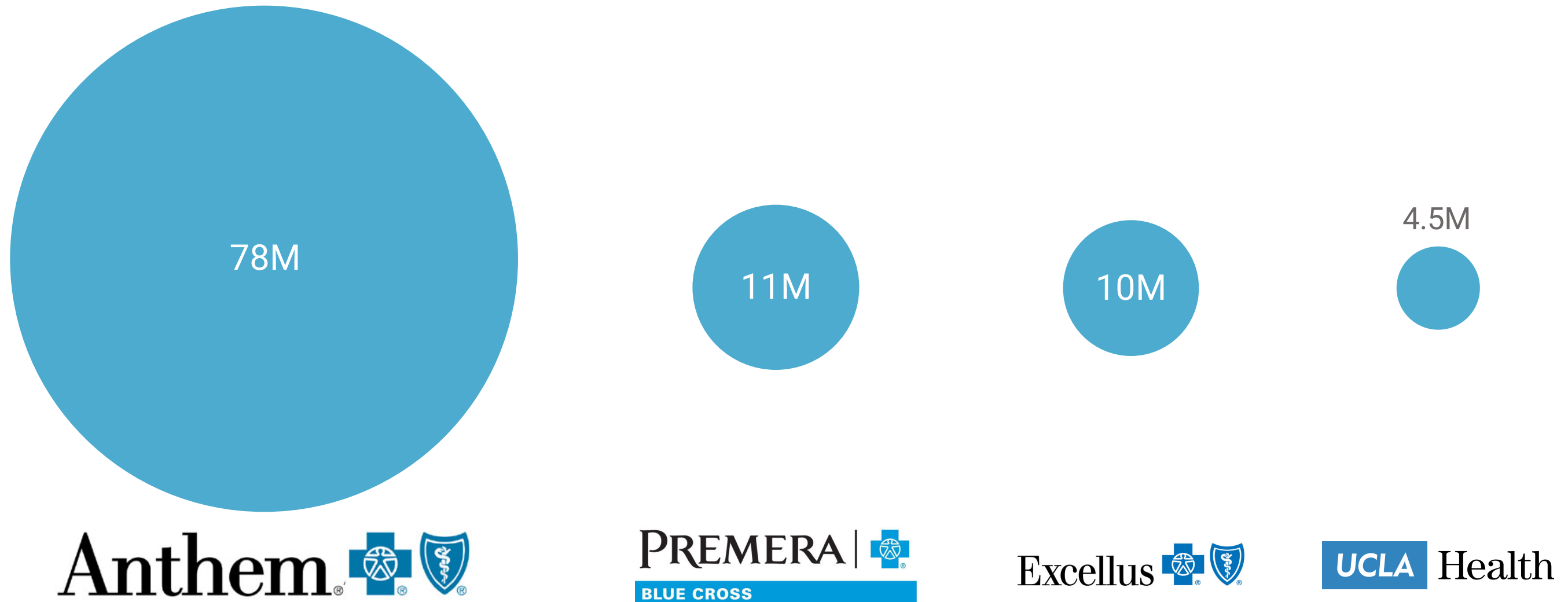

How Will We Adapt To Increasing Life Expectancies?

49 Years

Overall Life Expectancy
1900

79 Years

Overall Life Expectancy
2016

??? Years

Overall Life Expectancy
2100



INDUSTRIAL INTERNET OF THINGS

ASSET-HEAVY INDUSTRIES ARE BEHIND IN TECH

Sector	Overall digitization ¹	Assets		Usage			Labor			GDP share %	Employment share %	Productivity growth, 2005-14 ² %
		Digital spending	Digital asset stock	Transactions	Interactions	Business processes	Market making	Digital spending on workers	Digital capital deepening			
ICT										5	3	4.6
Media		1								2	1	3.6
Professional services										9	6	0.3
Finance and insurance										8	4	1.6
Wholesale trade										5	4	0.2
Advanced manufacturing					4					3	2	2.6
Oil and gas		2								2	0.1	2.9
Utilities										2	0.4	1.3
Chemicals and pharmaceuticals										2	1	1.8
Basic goods manufacturing										5	5	1.2
Mining										1	0.4	0.5
Real estate	●									5	1	2.3
Transportation and warehousing	●									3	3	1.4
Education	●									2	2	-0.5
Retail trade	●									5	11	-1.1
Entertainment and recreation										1	1	0.9
Personal and local services										6	11	0.5
Government	●									16	15	0.2
Health care										10	13	-0.1
Hospitality	●	6								4	8	-0.9
Construction										3	5	-1.4
Agriculture and hunting										1	1	-0.9

Relatively low digitization  Relatively high digitization

● Digital leaders within relatively undigitized sectors

Source: McKinsey

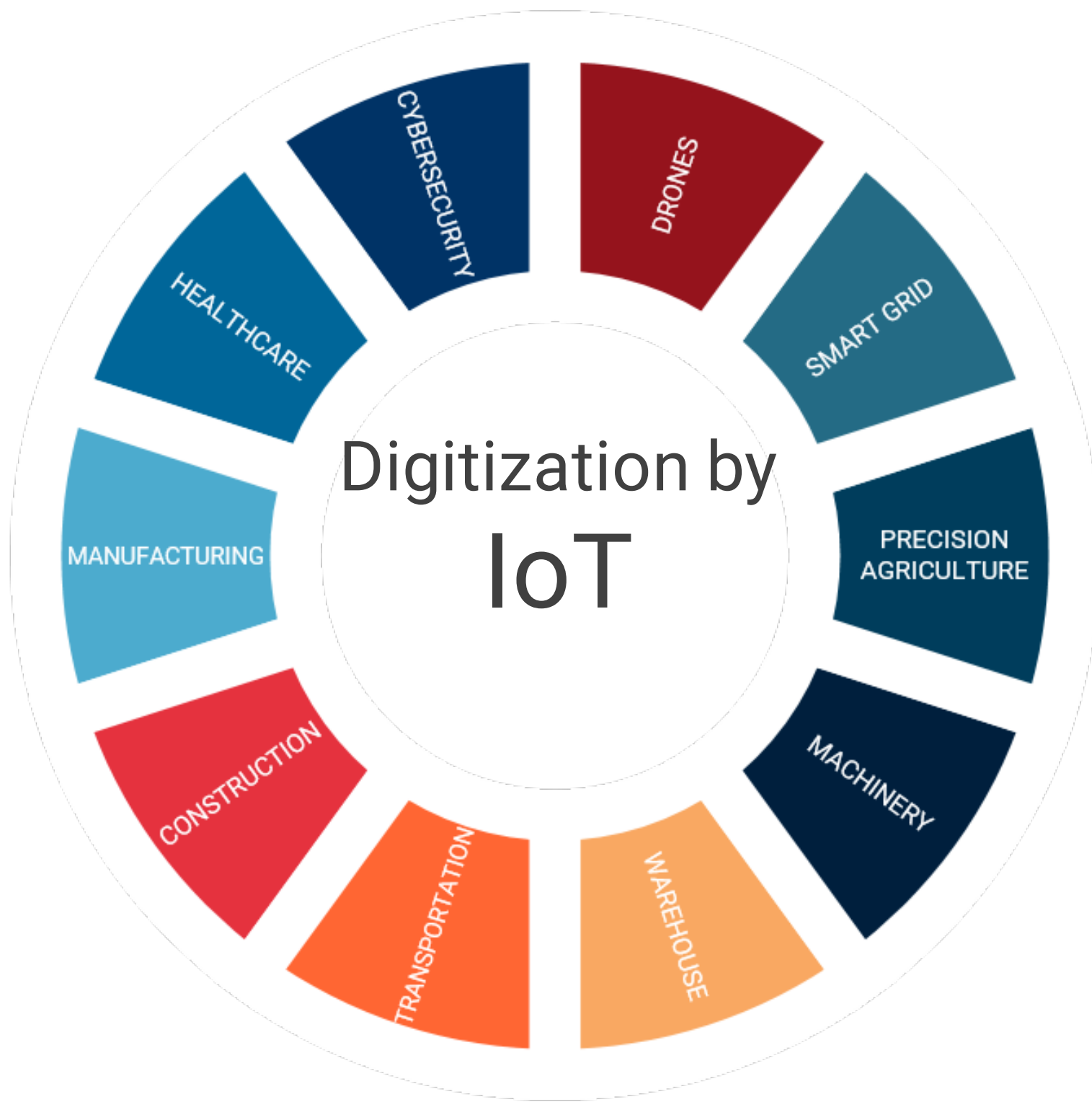

FROM POWER GRIDS TO TO HEALTHCARE: IOT IS DIGITIZING INDUSTRIES

Nearly every industry will see increased digitization. Manufacturing is just the start.

Adjacent verticals such as telecoms, data centers, and agribusiness are all being improved with better software, hardware & sensor networks.

TAILWINDS FOR THE INDUSTRIAL IOT

↓ Sensor Cost

↓ Computing Cost

↓ Networking Cost

A slew of innovations ranging from the smartphone to big data analytics coupled with the ability to outfit industrial equipment with sensors are now making it possible to capture and use the immense volumes of data has finally become feasible.

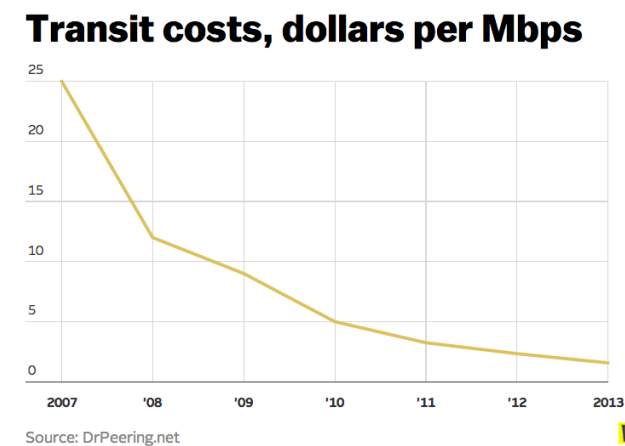
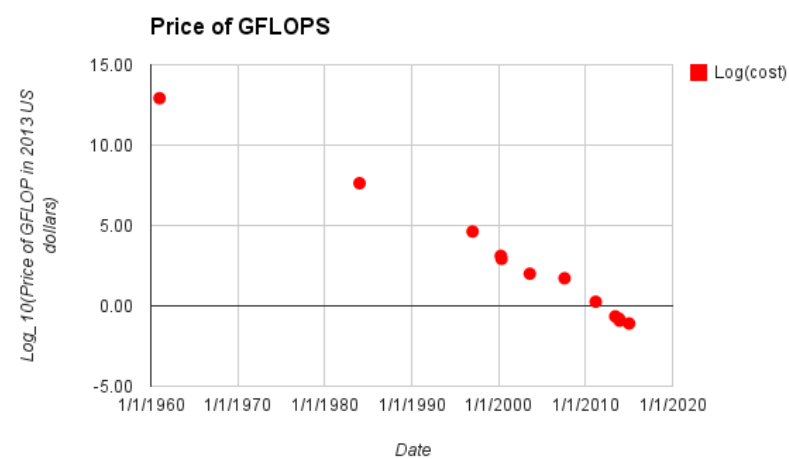
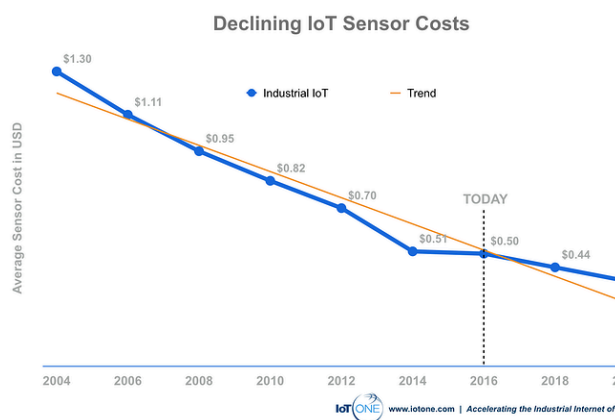



“A new jet engine might have a hundred sensors on it. These sensors have the capability to take continuous data about the heat of an engine, fuel consumption, the wear of the blades, the environment it’s taking off in—a series of things. **And one flight between New York City and Chicago produces a terabyte of data.**”

Jeff Immelt

CEO, General Electric

CORPORATES ARE BATTLING TO PROVIDE IIoT PRODUCTS AND SERVICES



GE
Predix



PTC
Thingworx

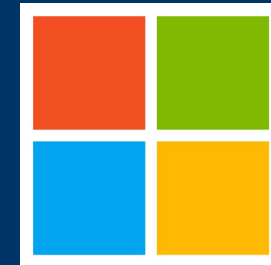

MSFT
Azure

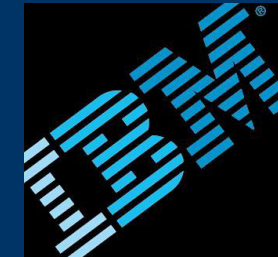

IBM
Watson IoT



IoT Cloud, Jasper



Android Things



AWS IoT



IoT Cloud

IIoT's hot categories

IIoT ANALYTICS

CYBERSECURITY

DRONES

ROBOTICS



IIoT Startup equity funding since 2012:

\$6.2 BILLION

across

919 DEALS



IIOT ANNUAL GLOBAL FINANCING HISTORY

2012 - 2016

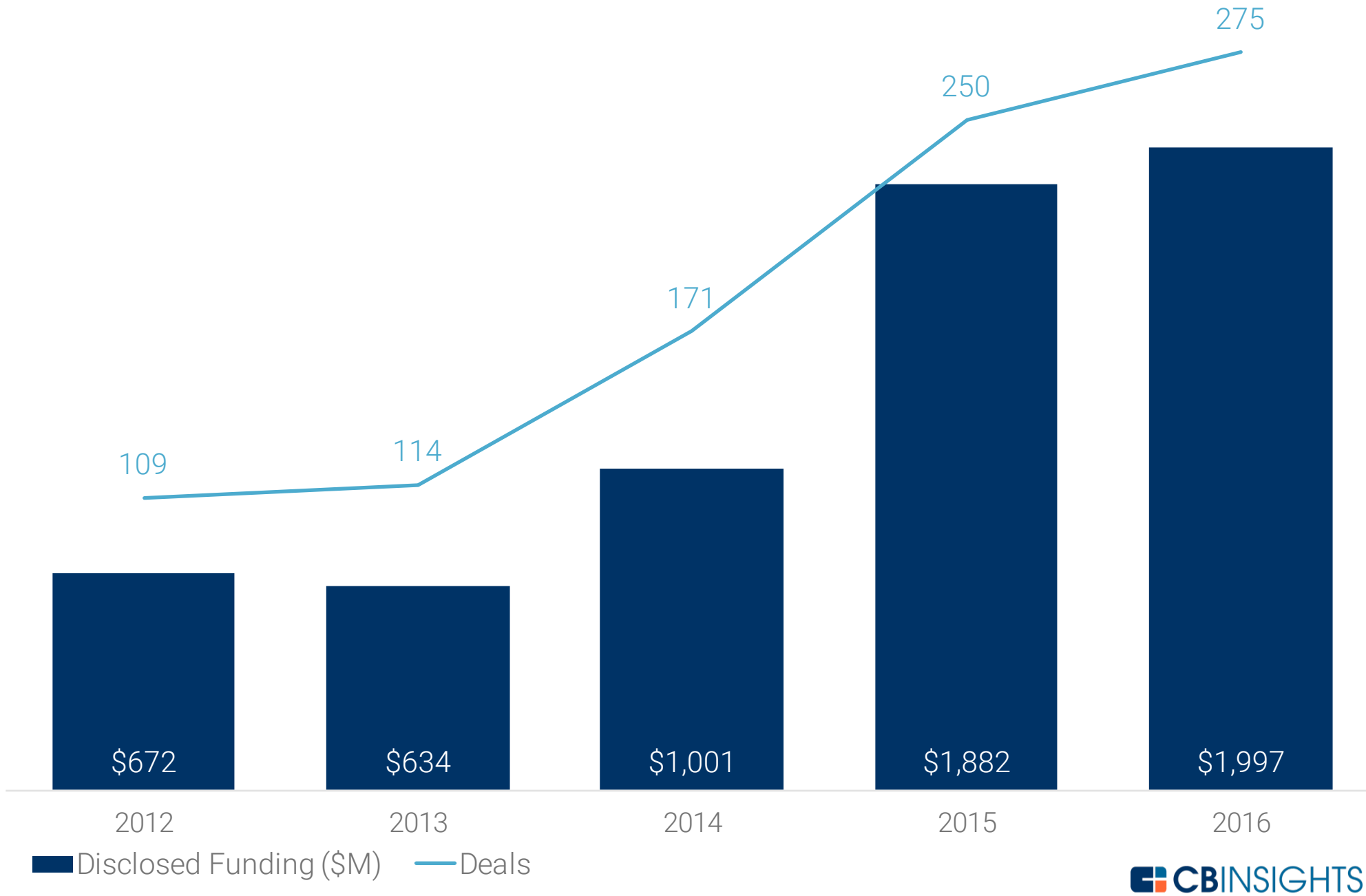

INDUSTRIAL IOT IS ALREADY SEEING ~\$2B INVESTED ANNUALLY

IIoT startups saw a combined ~\$2B dollars invested privately in 2016.





Create Feed

Agriculture Tech

Farmeron M&A

Farmeron is a provider of SaaS solutions for farmers, giving users statistics and actionable production reports to guide farm decision makin...

↳ Virtus Nutrition

6 days ago 1 mention Remind me

OnFarm Systems \$0.13M

OnFarm Systems combines a comprehensive array of leading farm hardware technologies into a single grower-friendly management and decision pl...

– 500 Accelerator

14 days ago 1 mention Remind me

Cogent3D \$0.35M

Cogent3D is the maker of multiple iOS applications like iCronTrak, iGeoTrak, PrecisionEarth, and iSBoam. The company's solutions have...

– Undisclosed Investors

21 days ago 1 mention Remind me

S4 \$1.20M

S4, previously known as Solapa4, has developed a decision making geo-referenced platform for the agricultural producer. The company integrat...

– Cultivation Capital & 1 other

22 days ago 1 mention Remind me

S4 \$0.05M

S4, previously known as Solapa4, has developed a decision making geo-referenced platform for the agricultural producer. The company integrat...

– Arch Grants

Internet of Things

Senseware \$2.09M

Senseware creates a sensory system for surroundings. A modular plug-and-play wireless sensor-based system that helps users expose the myriad...

– Undisclosed Investors

4 days ago 1 mention Remind me

Bitfinder \$6.23M

Bitfinder's portable device and software platform detect airborne and environmental irritants. Awair is a smart device that monitors the air...

– Altos Ventures

6 days ago 1 mention Remind me

Pristine \$0.52M

Pristine has developed and provides a telehealth solution that leverages Google Glass to improve time-to-care, leading to lower costs...

– Undisclosed Investors

8 days ago 1 mention Remind me

MedMinder Systems \$0.50M

MedMinder Systems provides services that simplify medication management and improve medication adherence. The company offers an easy-to-use...

– Undisclosed Investors

11 days ago 2 mentions Remind me

MATTERNET \$9.48M

Matternet is a 21st century transportation system that will transform the good are moved locally. Matternet is creating an automated deliver...

– Undisclosed Investors

Healthcare Exits

Maternal Fetal Medicine of Southwest Florida M&A

Maternal Fetal Medicine is a sub-specialty of obstetrics that focuses on diagnosing, treating and caring for women and unborn babies who are...

↳ MEDNAX

Today 1 mention Remind me

Medpace \$161.00M IPO

Medpace is a global full-service clinical research organization providing Phase I-IV core development services for drug, biologic, and devic...

↳ Public

5 days ago 2 mentions Remind me

Protagonist Therapeutics \$90.00M IPO

Protagonist Therapeutics is a biotech company focused on developing differentiated al...

↳ Public

5 days ago 7 mentions Remind me

Forsight VISION5 M&A

ForSight VISION5 was founded in January of 2011 as the fifth company to emerge from the ophthalmic incubator ForSight Labs (www.forsightlabs...

↳ Allergan

5 days ago 1 mention Remind me

Signature Healthcare Solutions M&A

Signature Healthcare Solutions specializes in acute care hospital medicine and partners with hospitals in the Chicago market.

↳ TeamHealth Holdings

Medical Devices

Pursuit Vascular \$2.08M

Pursuit Vascular is developing a family of single-use products intended to protect patients from life-threatening infections and provide sub...

– Undisclosed Investors

4 days ago 1 mention Remind me

Clear Guide Medical \$0.03M

Clear Guide Medical develops technologies to provide image fusion and Computer-Assisted Instrument Guidance for minimally invasive medical p...

– Undisclosed Investors

4 days ago 1 mention Remind me

Atomo Diagnostics \$3.47M

Atomo Diagnostics is commercializing a range of easy to use rapid diagnostic devices and services that deliver clinical and economic value t...

– Global Health Investment Fund

4 days ago 4 mentions Remind me

Greater Alabama Lithotripsy \$0.32M

Greater Alabama Lithotripsy is a provider of minimally invasive urological services and products.

– Undisclosed Investors

4 days ago 1 mention Remind me

JenaValve Technology \$10.00M

JenaValve Technology develops, manufactures and markets transcatheter aortic valve implantation systems (TAVI) to treat patients suffering f...

– Edmond de Rothschild Investment Partners & 3 others

Payments

Red Dot Payment

Red Dot Payment is a Singapore payment processing compa... Southeast Asia. The compa... product...

– GMO VenturePartners & 3 o...

4 days ago 1 mention

FC Exchange

FC Exchange is an internationa... and payment company. FCE's... businesses and individuals, an... f...

↳ Global Reach Partners

4 days ago 2 mentions

Transfert Credit

Transfert Credit provides inter... top-up services.

↳ Ding

6 days ago 1 mention

Wangyudashi

Wangyudashi, which operates... wangyuhudong.com, is a spec... for internet cafe payments and...

– Shenzhen Capital Group Co...

6 days ago 3 mentions

Prepaid Technologies Company

Prepaid Technologies combine... relationships and payments sy... with innovative technology to r... paymen...

– Ballast Point Ventures

6 days ago 1 mention

What does the future of industry look like?

Click for Live Help

IMAGINE NO DELAYS, NO DOWN TIME

System & Asset Optimization is the promise of IoT

Fleets, Factories, and Machines could all have:

- Predictive maintenance
- No unscheduled down time
- Send technicians
- Optimize fleet usage
- Maximize safety

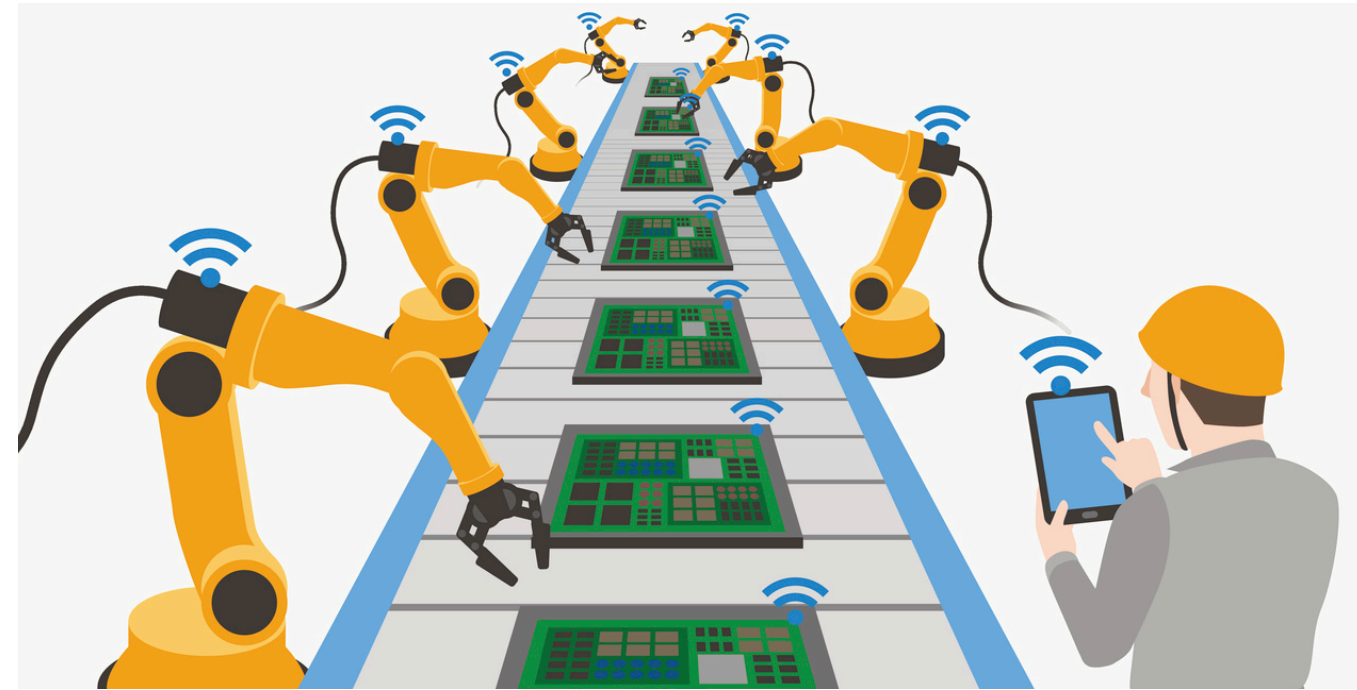

LESS DIRTY, DANGEROUS, AND DULL JOBS

Drones, robotics, and sensors replace tough jobs



FACTORIES AND WAREHOUSES

Robots get flexible and automate once-odd jobs



ASSET TRACKING OPTIMIZES EVERYTHING

Sensor-laden equipment simplifies hospital care

21 minutes/shift

Amount nurses on average spend searching for medical equipment



THE NEW USER INTERFACE



“People-to-people conversations, people-to-digital assistants, people-to-bots and even digital assistants-to-bots. That’s the world you’re going to get to see in the years to come.”

Satya Nadella

CEO, Microsoft

CONVERSATIONAL INTERFACES OF TODAY

MESSAGE



Slack bots



Messenger bots



Hipchat bots



Kik bot shop

VOICE ASSISTANTS



Alexa



Siri



OK Google



Cortana

49 CORPORATIONS USING BOTS ACROSS INDUSTRIES



Companies across a wide variety of industries are building bots on popular messaging apps like Facebook Messenger, Slack, Kik, and Hipchat, as well as on their own websites and apps.

“These days, every other pitch I get is some kind of ‘bot company.’”

Ping Li

General Partner, Accel Partners

--*O'Reilly BOTDAY Conference*





AI assistants, brainwaves, and beyond
THE UI OF THE FUTURE

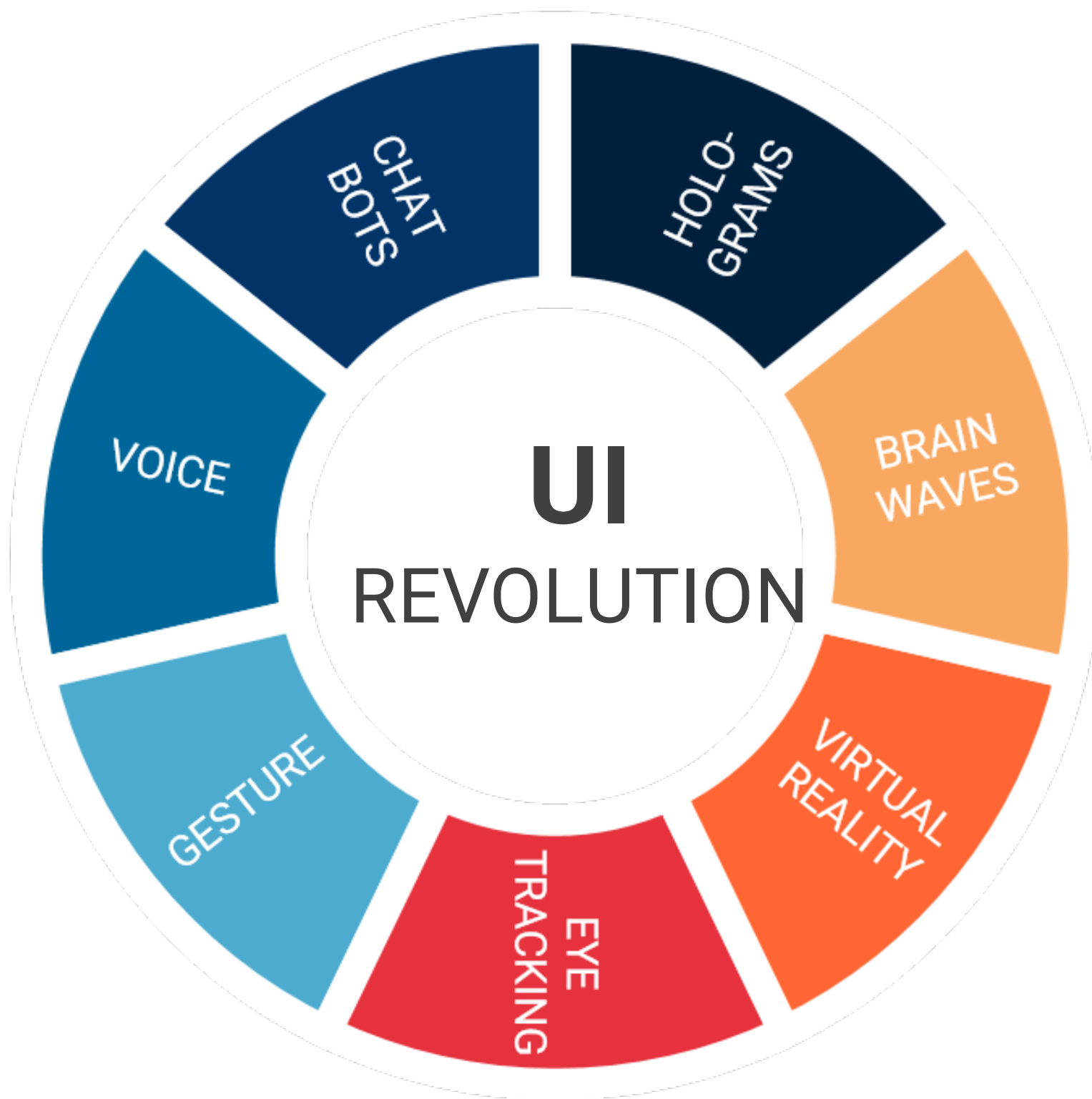

THE NEXT GENERATION OF USER INTERFACES

Voice assistants, gesture control, holograms, and more

Startup equity funding to UI2.0 since 2012:

\$1 BILLION

across

241 DEALS



UI 2.0: ANNUAL STARTUP FINANCING

2012-2016

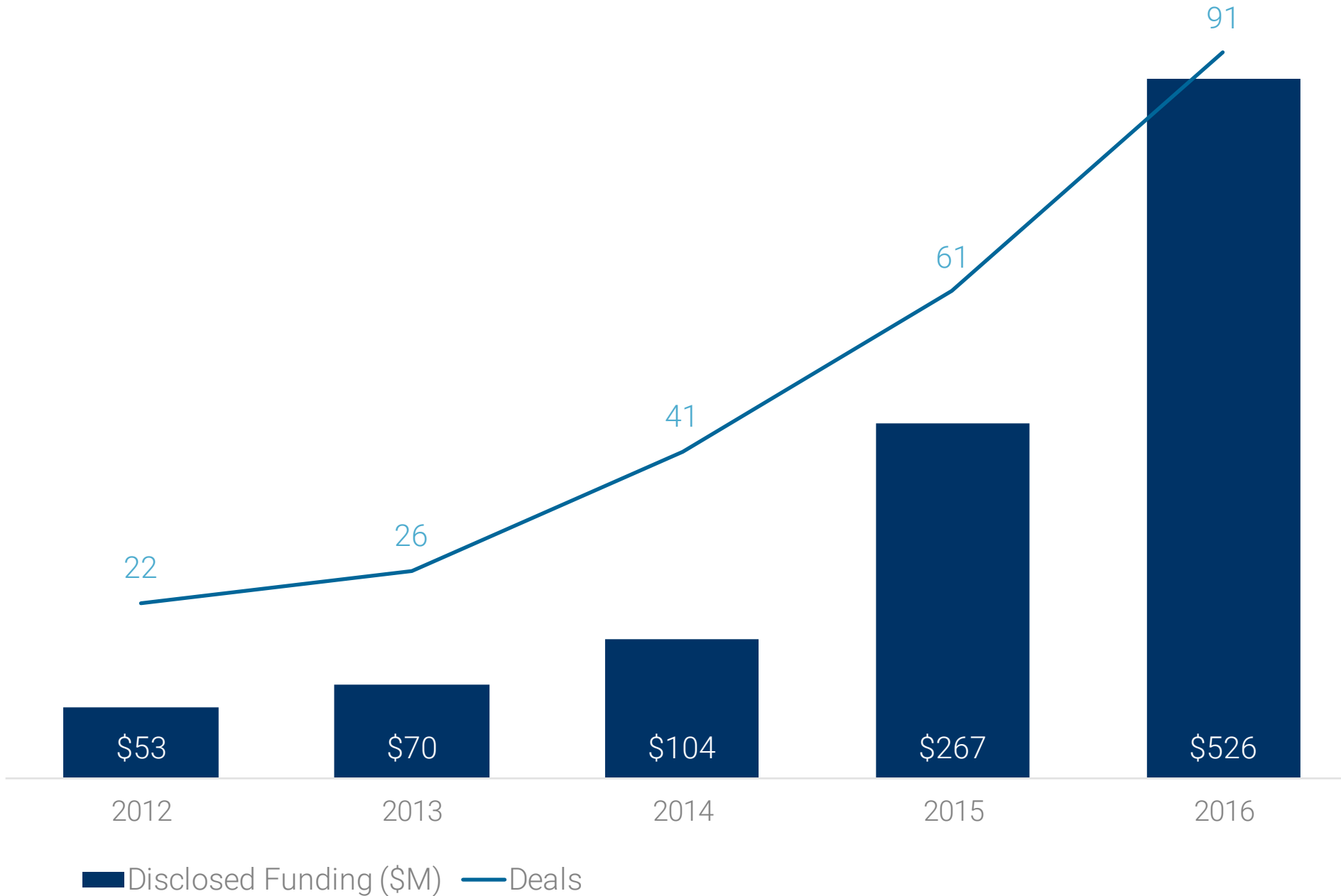

DEALS TO STARTUPS DEVELOPING NEW USER INTERFACES REACHES RECORD HIGH IN 2016

Deals were up 4x, from less than 25 in 2012 to over 90 in 2016.

UI 2.0: 2016 Startup Landscape

TEXT/ CHAT BOTS

digit 



Ozlo



 mezi

GESTURE & EYE TRACKING

Meta
AUGMENTED REALITY

uSens Inc

 eyeSight

F O V E

VOICE- ENABLED

Rokid

 Mobvoi
出门问问

hiku

 TACT

BRAINWAVE/ NEURO-SIGNALS

muse™
the brain sensing headband

EMOTIV

NeuroSky®
Body and Mind. Quantified.

SYNETIQ

ALEXA AND THE VOICE REVOLUTION

From calling an Uber to cooking tips, Amazon's Alexa is a new App Store for voice.



"Alexa, ask My Chef what's expiring."



"Alexa, ask Uber to request a ride."



"Alexa, ask Fitbit how I slept last night."



"Alexa, what's in the news?"



"Alexa, ask the bartender, what's in a Tom Collins?"



"Alexa, tell Tide I have a juice stain."

MUSCLE SIGNALS AS AN INTERFACE

Wearable technology that uses electric signals generated by muscles.



Select Investors:



WELL-FUNDED UI 2.0 STARTUPS

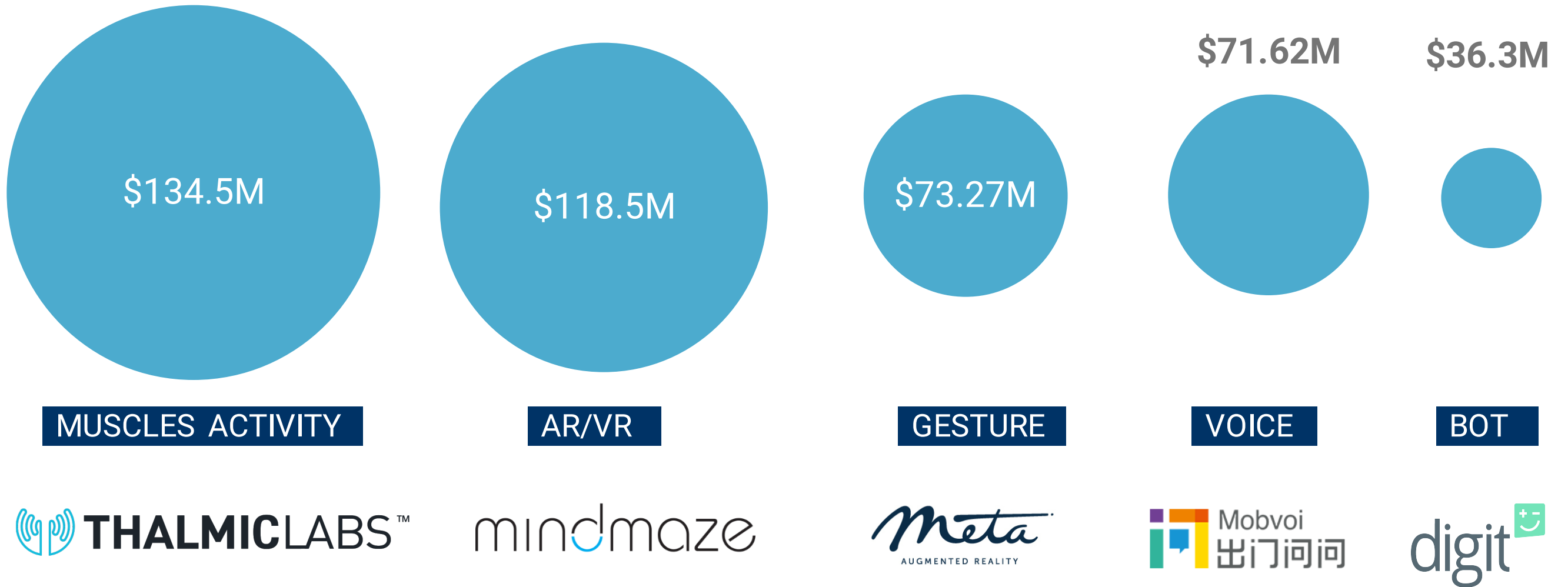

THE ENEMY OF MY ENEMY IS MY ???
COMPETITIVE LINES BEING REDRAWN

AMAZON PATENTS THE DEATH STAR

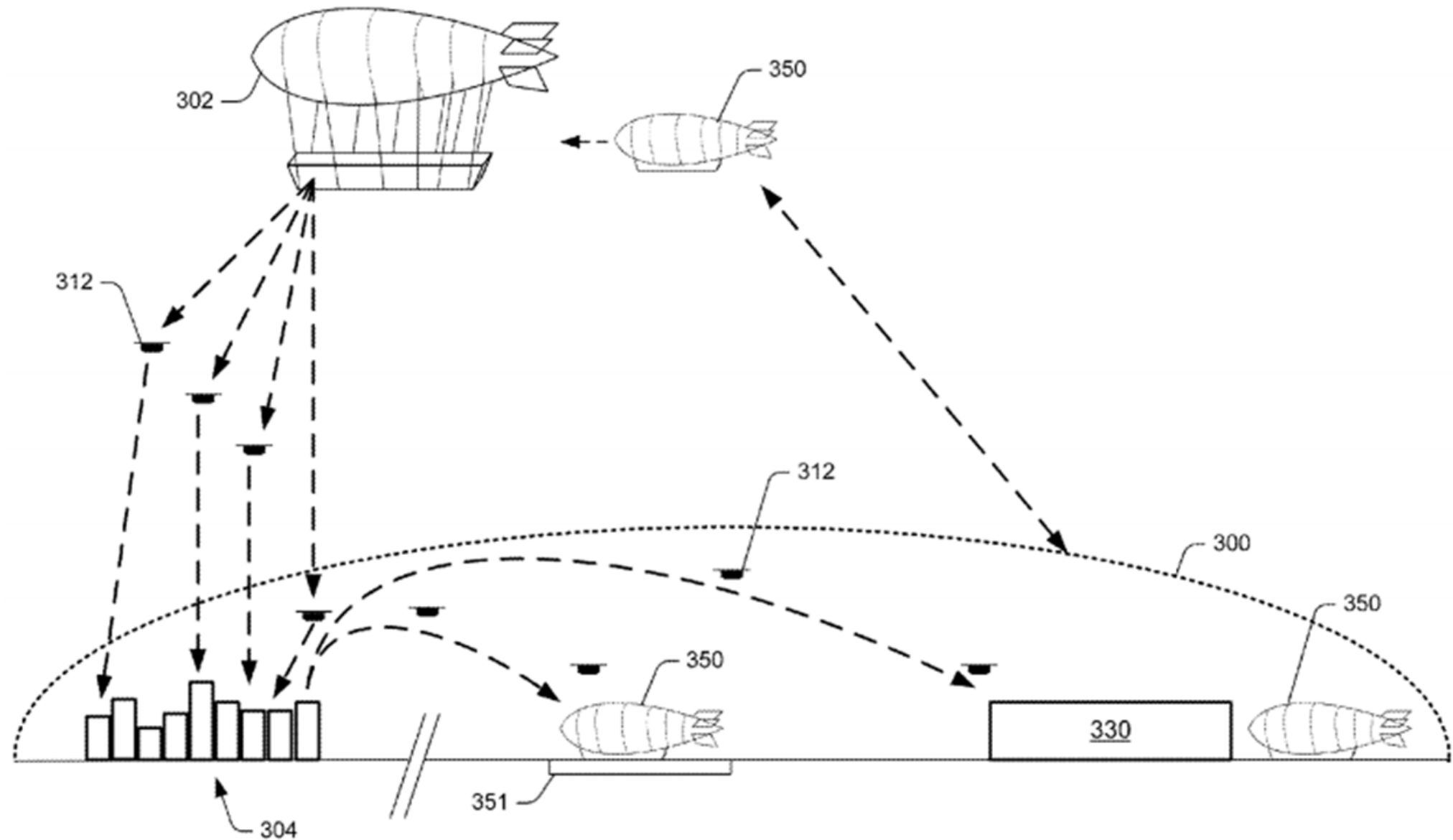

COMPETITIVE LINES ARE BEING RE-DRAWN

This is happening in many industries.

Software over soft drinks. Nestlé SA, Coca-Cola Co. and others selling consumer products in India say they are seeing less activity as more consumers opt to spend on data plans instead of shampoo, soft drinks and other goods. As [the WSJ's Preetika Rana reports](#), a new wave of affordable smartphones has brought hundreds of millions of Indians online for the first time. “There was a time when kids would come here and blow their pocket money on chips and chocolate,” said Anup Kapoor, who runs a mom-and-pop grocery shop in New Delhi. These days, “they spend every last rupee on a data recharge instead.”

INSURANCE COMPANIES FILING PATENTS FOR AN AUTONOMOUS FUTURE

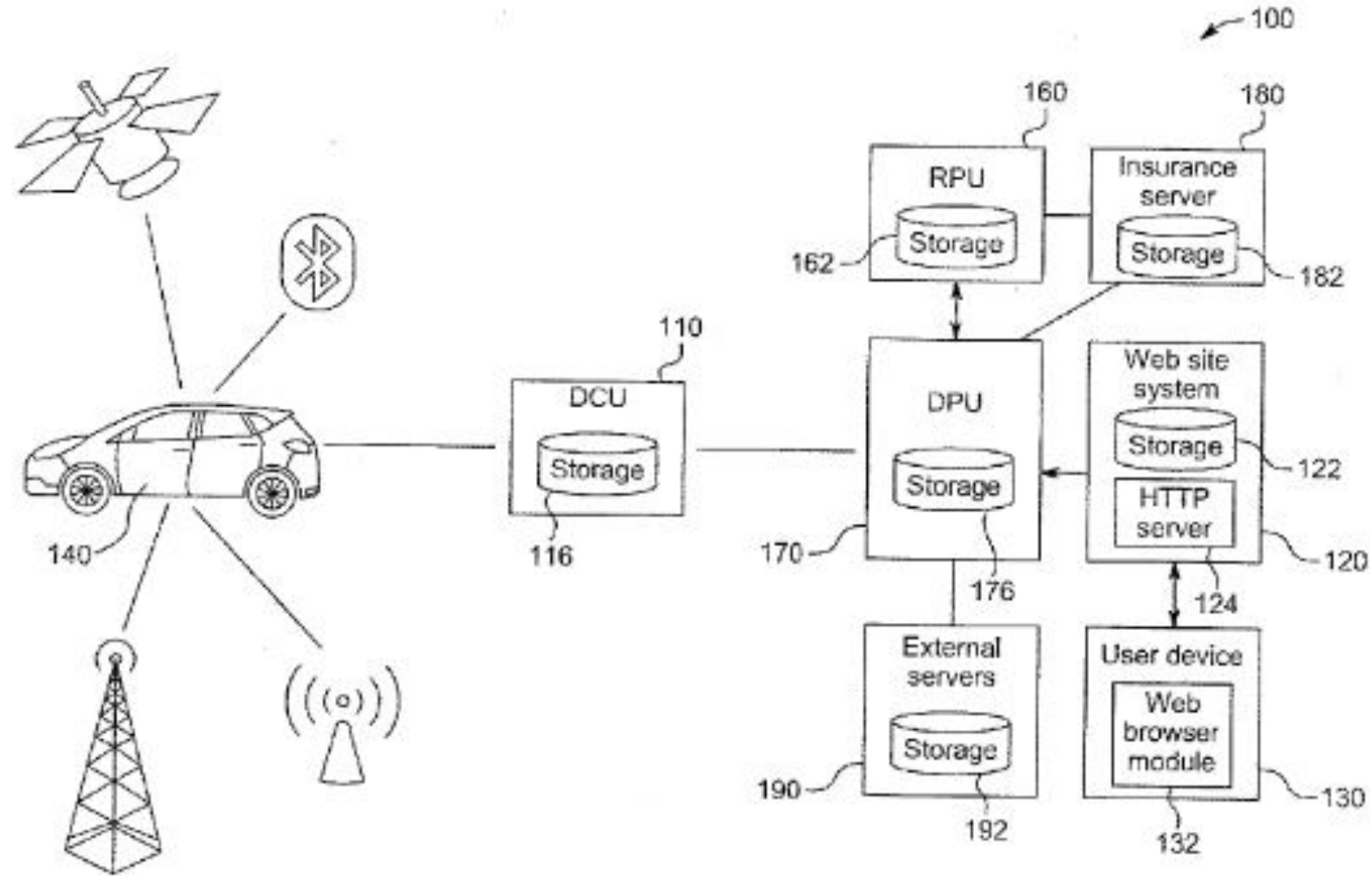

Above illustration from Hartford Insurance patent

A photograph of three elderly men, shirtless and wearing Abercrombie Physical Ed. sweatpants, holding a thick rope. The image is overlaid with a blue tint. The men are positioned from left to right, each holding a section of the rope. The man on the left is looking upwards and to the right, the middle man is looking towards the right, and the man on the right is smiling and looking towards the left. The text is overlaid in white on the left side of the image.

"You clearly have a group that cares less about logo and brand and more just about quality, and they [haven't been] prioritizing apparel [instead, they're] using disposable income on electronics like smartphones, health and fitness, [and] even more so on experiences."

- Betty Chen, Mizuho Securities

INCUMBENT AUTO COMPANIES HAVE TO FIGHT BATTLES ON 2 FRONTS



control device	fuel cell	battery pack
wheel suspension	catalytic reduction	electric vehicle
fuel tank	drive train	battery cell
electric motor	fuel cell stack	thermal management
drive device	powertrain system	battery pack enclosure
hybrid vehicle	catadioptric camera	energy storage
control element	lightweight valve	thermal runaway
hybrid drive	cam element	metalair battery pack



UNUSUAL COMPETITORS WILL EMERGE

GM ACQUIRED CRUISE AUTOMATION FOR \$1B. AIRLINES WILL SOON BE COMPETING WITH AUTONOMOUS VEHICLES.



MAINTAINING RELEVANCE
THE CORPORATE NEED TO INNOVATE

Average company lifespan on S&P 500 Index (in years)

In the last 15 years,
**52% of S&P 500 companies
have disappeared**

1955

61-year lifespan in S&P 500

vs

2015

17-year lifespan in S&P 500

Projections based
on current data

Year (each data point represents a rolling 7-year average of average lifespan)

DATA: INNOSIGHT/Richard N. Foster/Standard & Poor's



Top 5 Publicly Traded Companies (by Market Cap)



Tech



Other

2006



\$446B



\$383B



\$327B



\$293B



\$273B

2011



\$406B



\$376B



\$277B



\$253B



\$228B

Technology is eating **EVERY INDUSTRY**
And you're trying to **BITE BACK**

2016

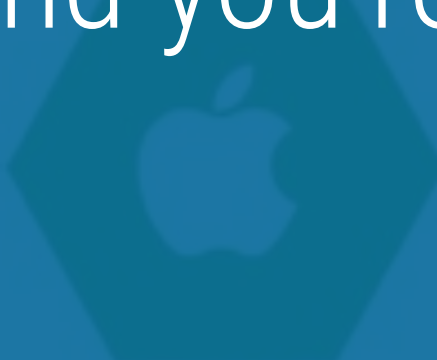

\$582B

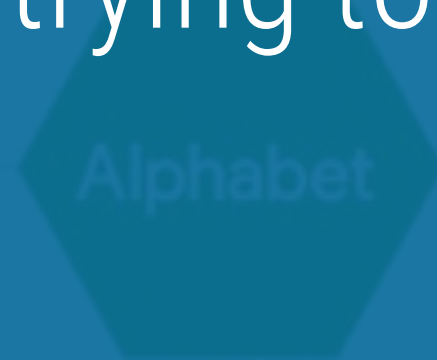

\$556B



\$452B



\$364B



\$251B

NON-TECH ACQUIRERS PONY UP \$1B+

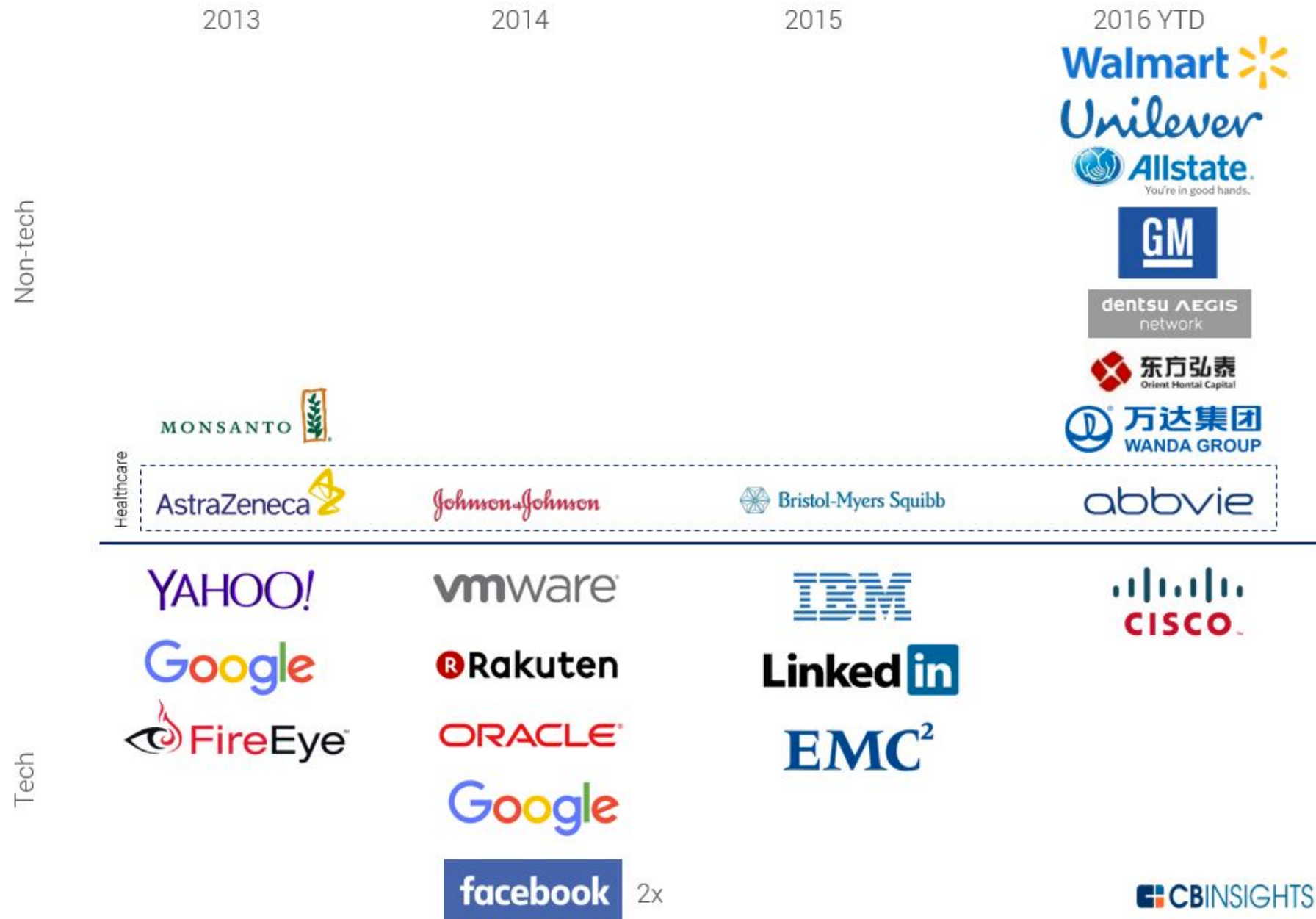

BIG BANKS ACTIVELY INVESTING IN FINTECH

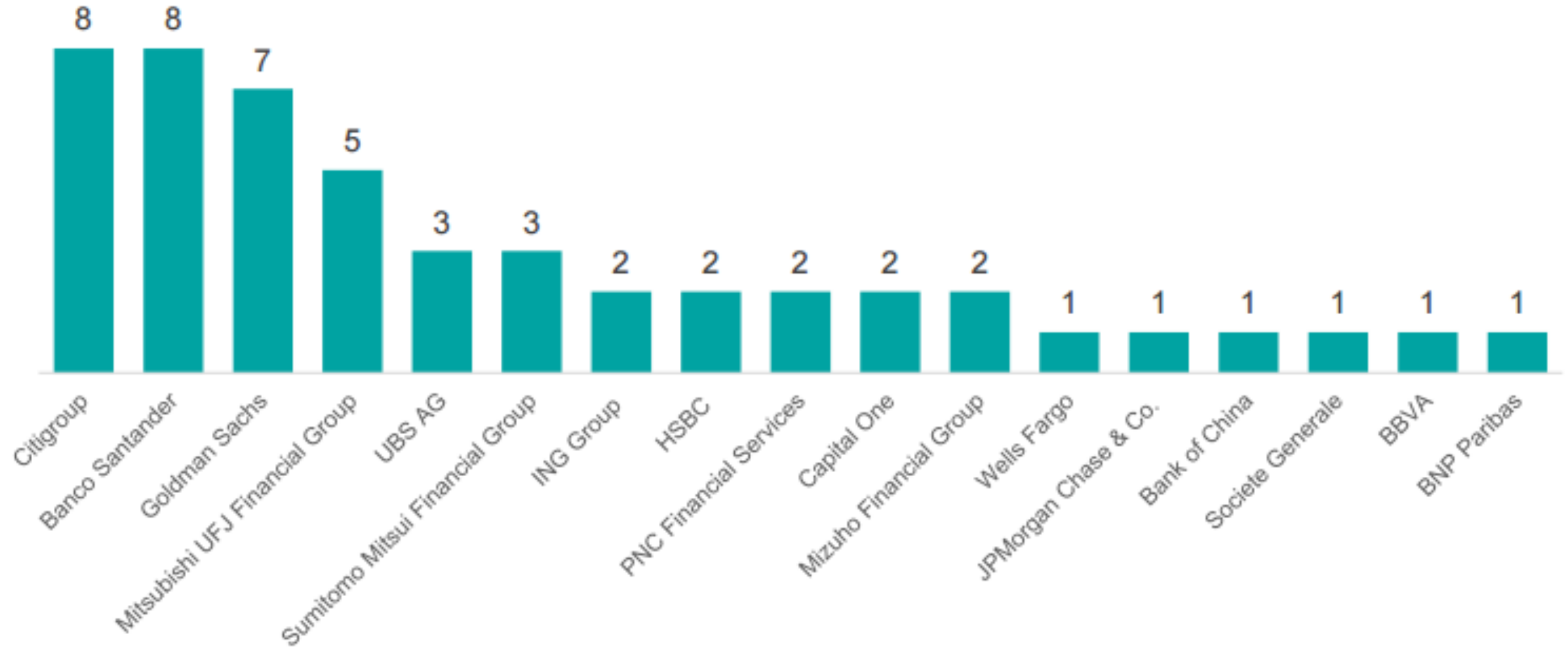



AIRBNB VALUATION HISTORY

Seed deal at \$2.99M valuation in 2009

NEW PLATFORMS COME QUICK
AIRBNB'S VALUATION IS GREATER THAN HYATT AND STARWOOD/MARRIOTT (COMBINED)

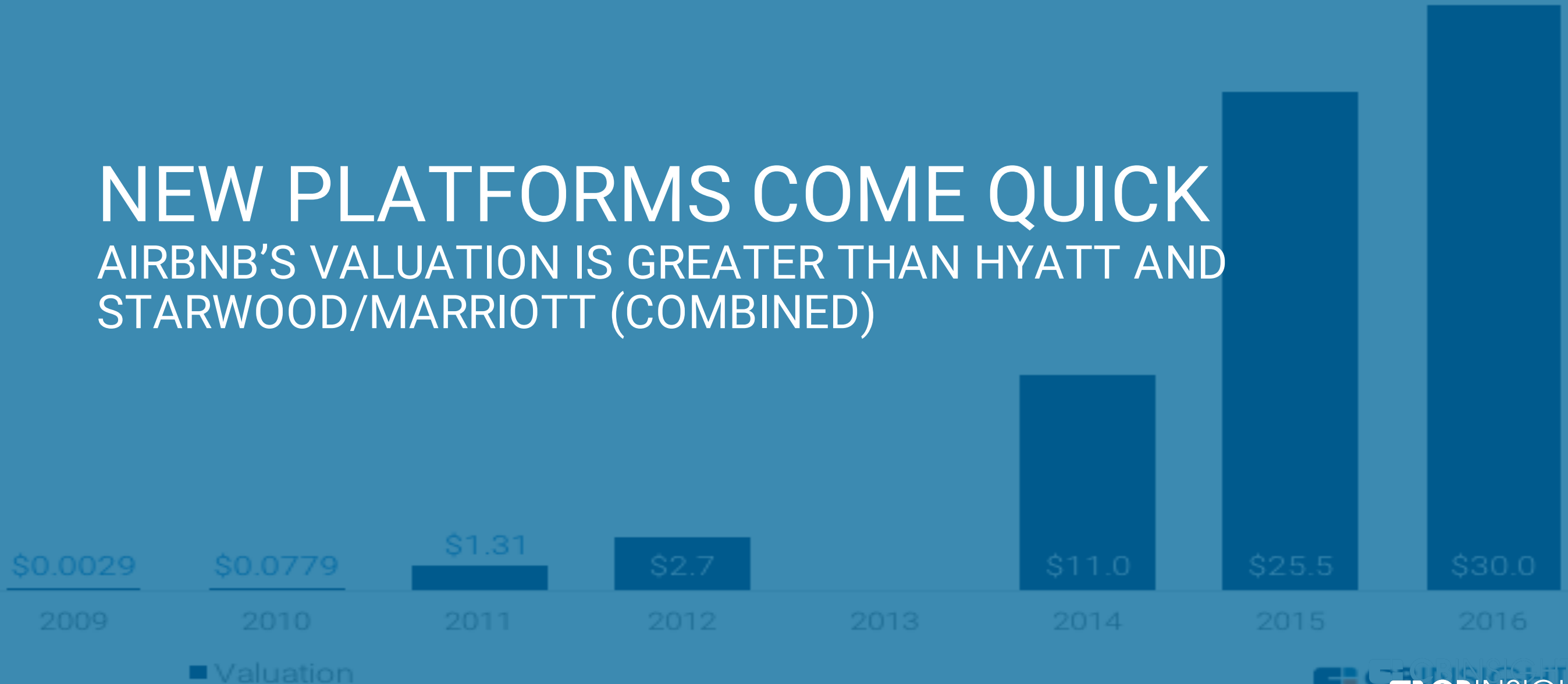

UNBUNDLING FEDEX

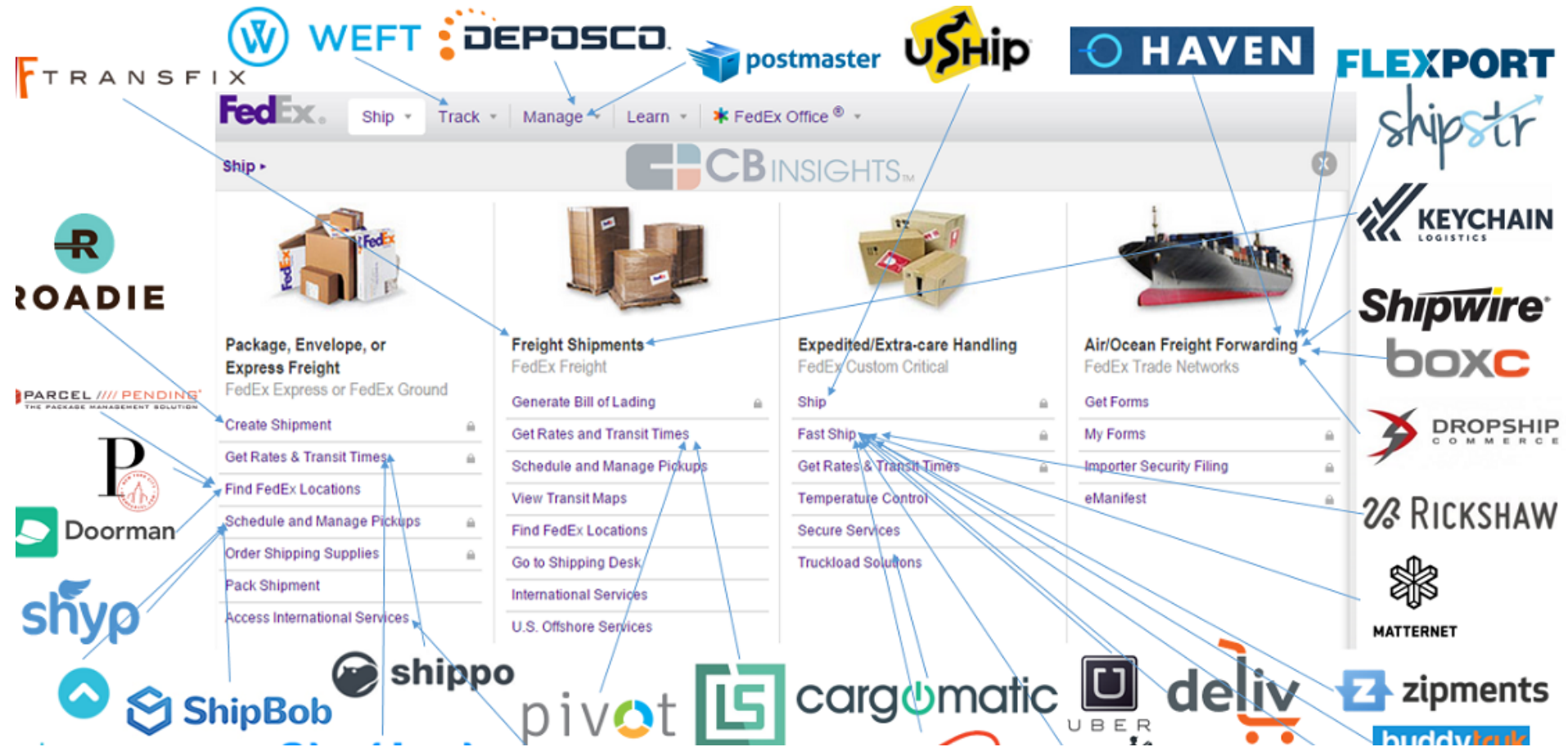

Source: <https://www.cbinsights.com/blog/startups-disrupting-fedex-ups/>

UNBUNDLING THE AUTOMOBILE

Created by
CB INSIGHTS
 www.cbinsights.com

Unbundling The Automobile

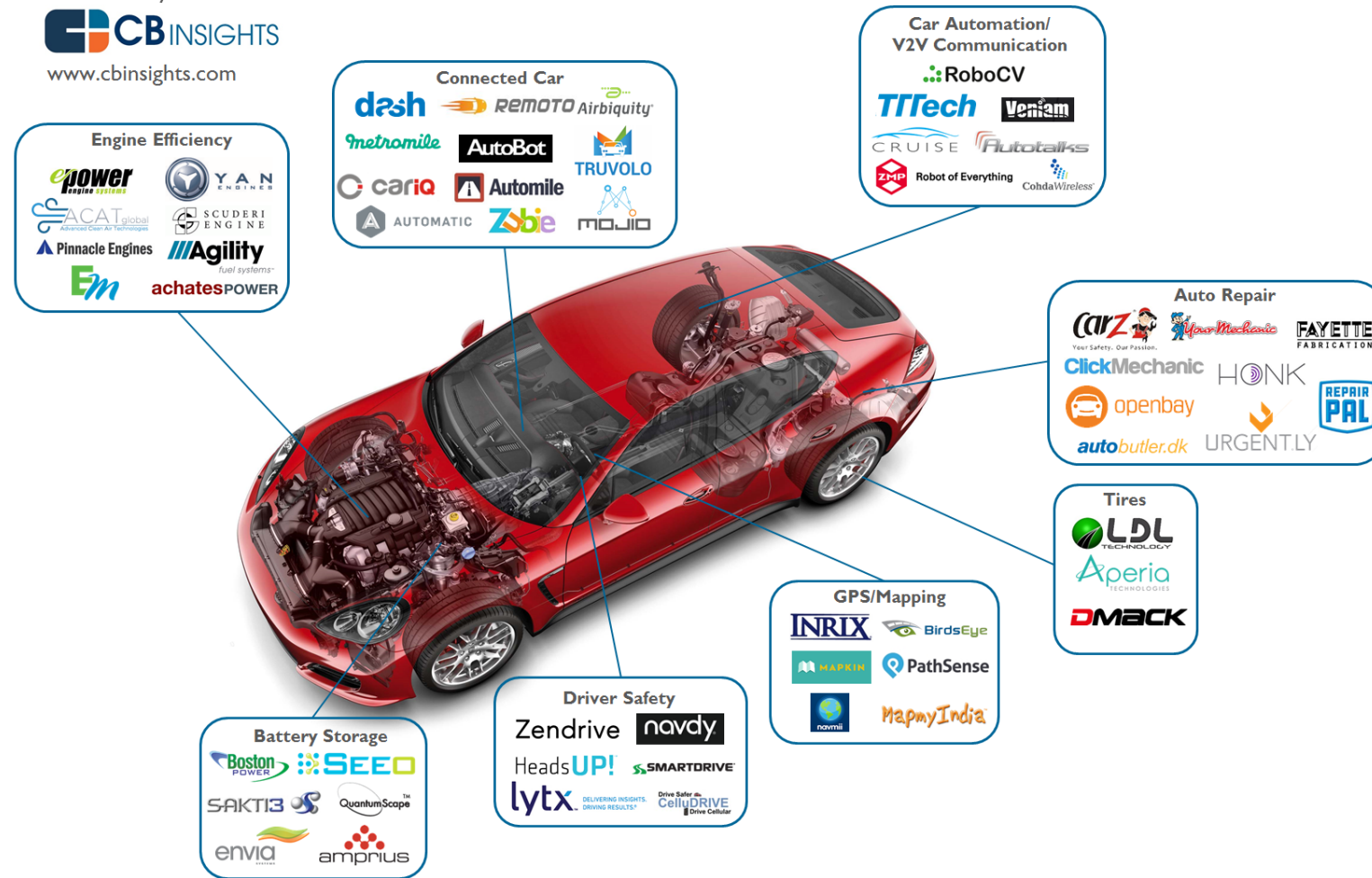

Source: <https://www.cbinsights.com/blog/startups-drive-auto-industry-disruption>

UNBUNDLING HONEYWELL

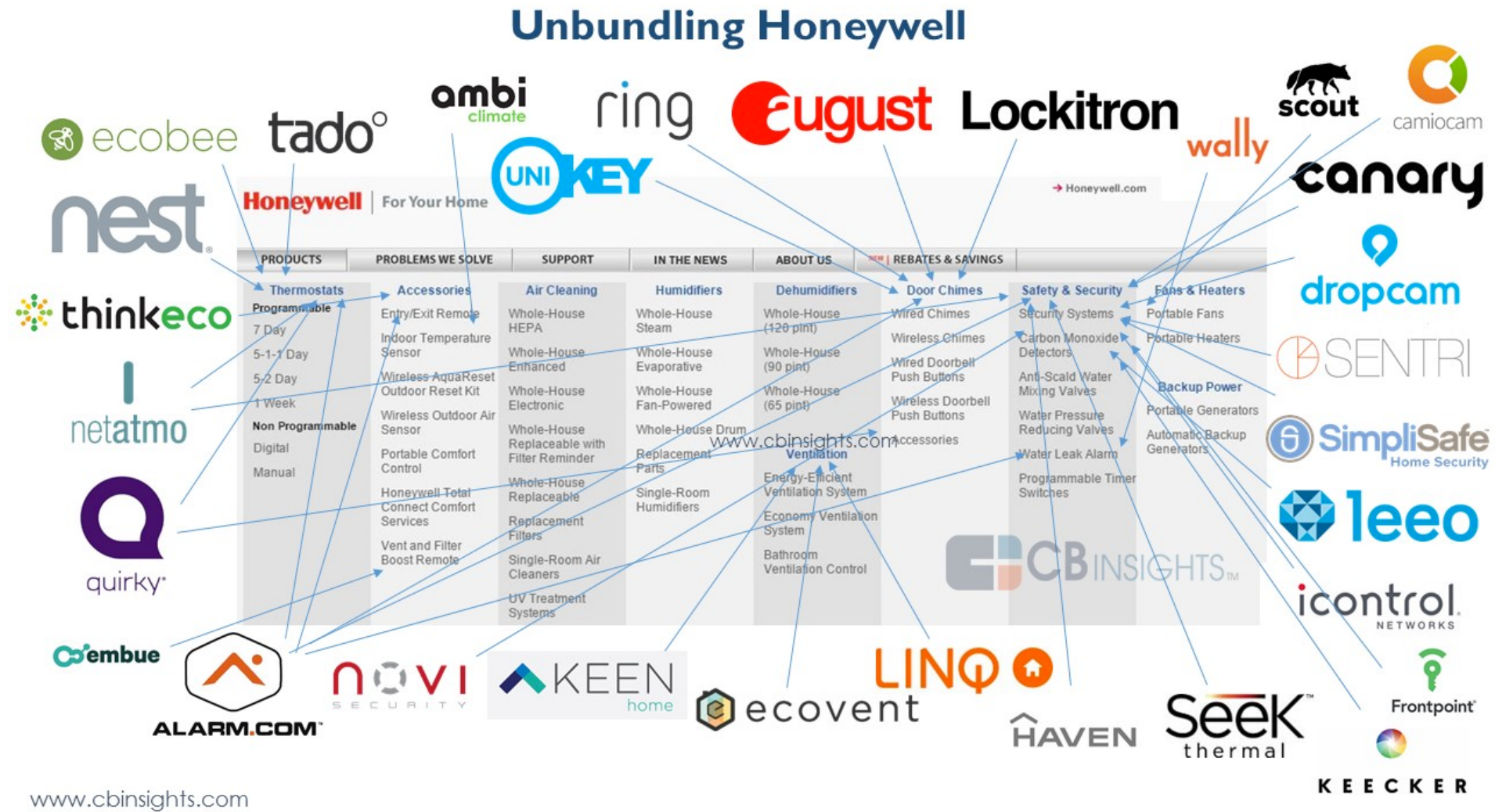

Source: <https://www.cbinsights.com/blog/disrupting-honeywell-startups>

UNBUNDLING P&G



Source: <https://www.cbinsights.com/blog/disrupting-procter-gamble-cpg-startups>

UNBUNDLING STARWOOD

Startups That Are Unbundling The Hotel



Created by
 CBINSIGHTS
www.cbinsights.com



Source: <https://www.cbinsights.com/blog/unbundling-the-hotel>

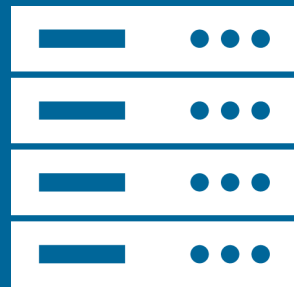

PHASE 1
Mainframe

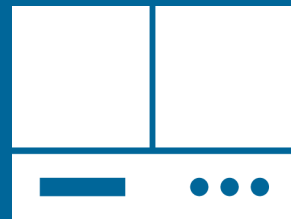

PHASE 2
**Mini
Computer**



PHASE 3
PC
Software



PHASE 4
Internet
Web



PHASE 5
Mobile
Apps



PHASE 6
**Connected
Platforms**
Hardware & Software

**READY FOR THE
NEXT PHASE?**

TECHNOLOGY ADOPTION IS QUICKER THAN EVER

Time is not on your side

CONSUMPTION SPREADS FASTER TODAY

PERCENT OF U.S. HOUSEHOLDS

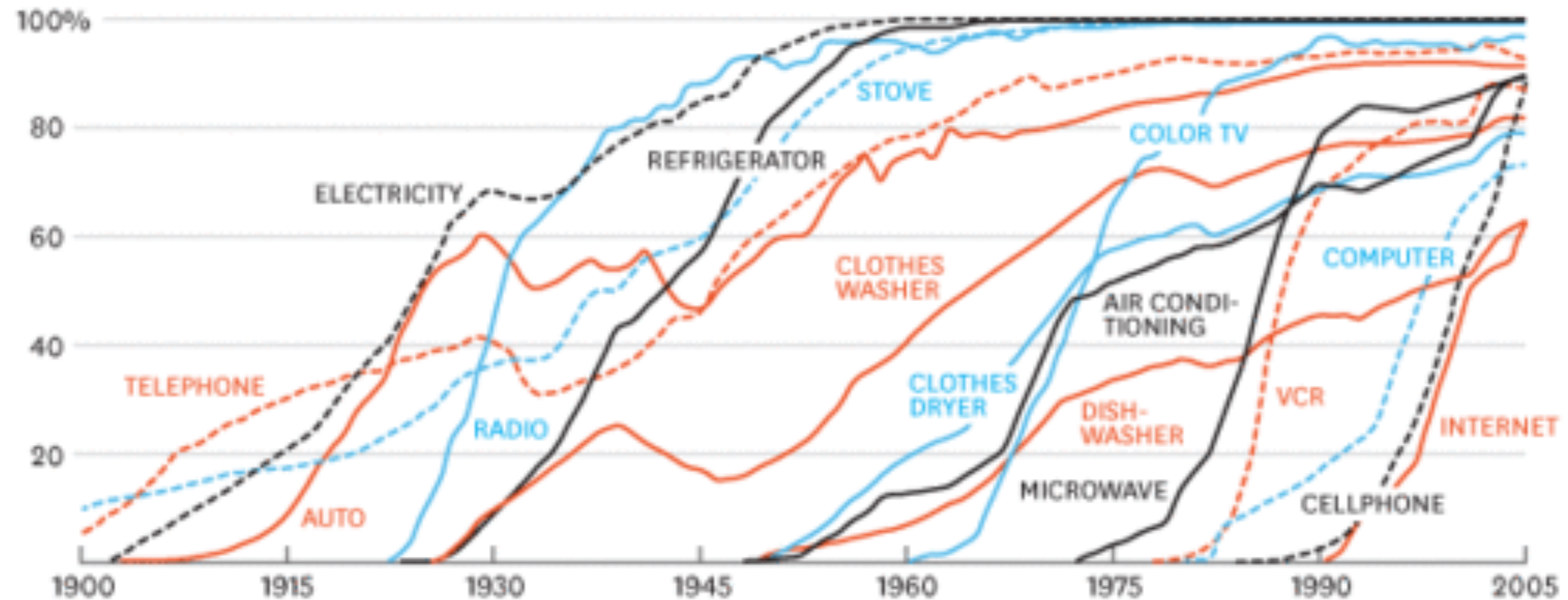

SOURCE MICHAEL FELTON, THE NEW YORK TIMES

HBR.ORG

...AND THAT PACE IS ACCELERATING

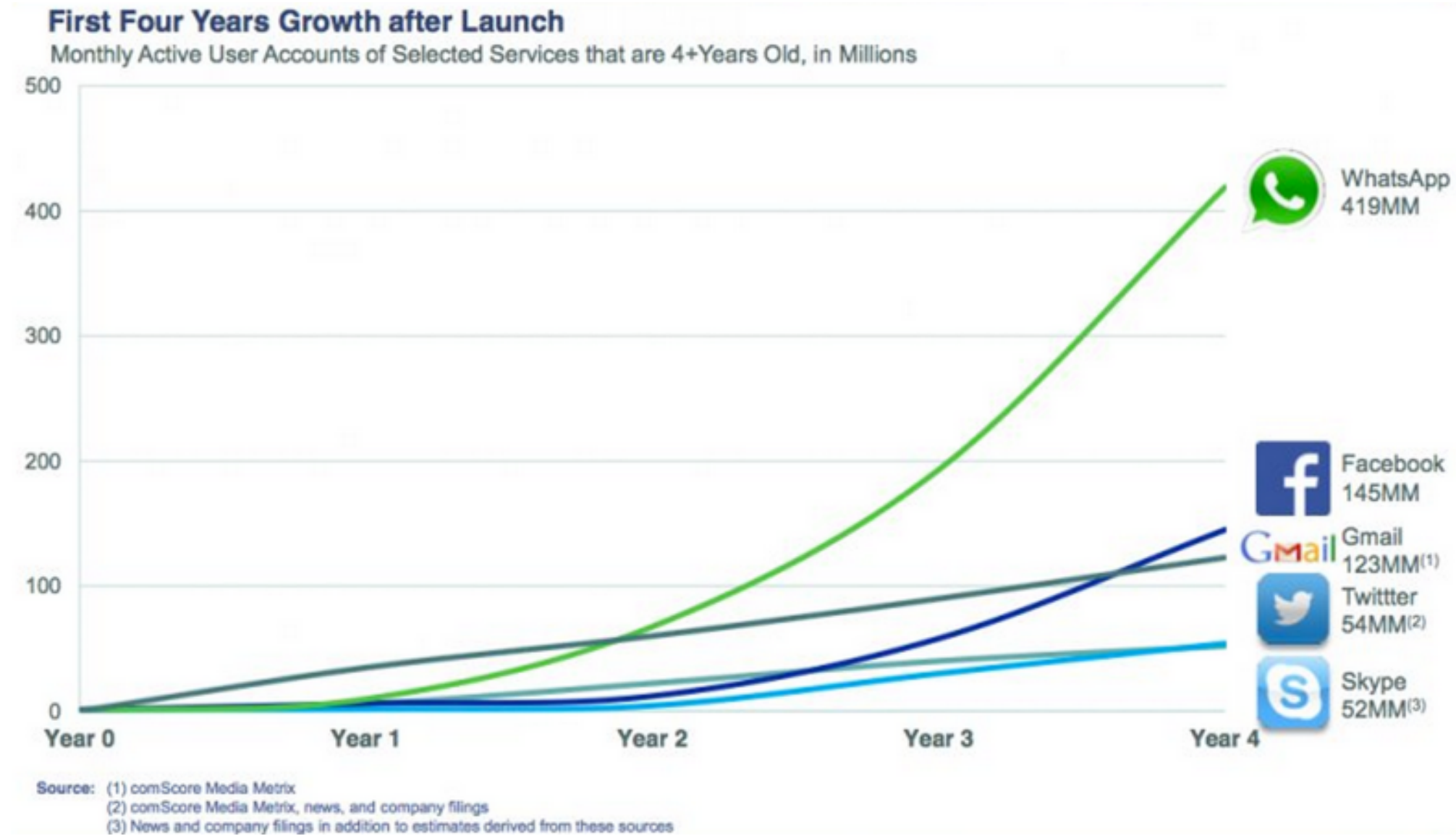

Source: Facebook

ABOUT ME

Anand Sanwal

CEO / Co-founder, CB Insights

Ran American Express \$50M Chairman's Innovation Fund

Prior work in venture capital and M&A

Author of "Optimizing Corporate Portfolio Management" (Wiley 2007)

Graduate of Wharton (Finance/Accounting) and University of Pennsylvania (Chemical Engineering)



@asanwal



asanwal@cbinsights.com